

ASV115CF132: Standard VAV compact controller

How energy efficiency is improved

Allows demand-based volume flow control in order to optimise energy consumption in ventilation systems. Differential pressures of as little as 1 Pa can be controlled to allow minimal volume flows for the lowest possible duct pressure and energy consumption.

Features

- Supply and return air control for individual rooms such as offices, conference rooms and hotel rooms, in conjunction with a VAV box or a damper and flow probe. Pressure control in supply and return air ducts for low-noise, energy-efficient air distribution.
- Static measurement of differential pressure based on the capacitive method of measurement
- Can be used in areas with dirty or contaminated return air
- High-precision measurement of differential pressures with measuring ranges of up to 300 Pa
- Variable running times 30...120 s
- Brushless DC motor guarantees minimum energy consumption and a long service life
- Electronic torque limitation for safe operation
- Disengageable transmission for manual adjustment and damper positioning
- Integrated second controller for the following applications¹⁾:
 - Room-pressure control: can be ideally combined with EGP100 with symmetrical measuring range²⁾
 - Room temperature control: can be ideally combined with SAUTER Ni1000 sensor and AXS 215S continuous valve actuator
- Can be used as duct section pressure controller³⁾
- RS-485 bus interface for up to 31 subscribers in a segment with SLC (SAUTER Local Communication) protocol
- Very easy programming using the SAUTER CASE VAV software
- Constant air volume control via parameterisable inputs
- Adjustable end values of the differential pressure range
 - 50...150 Pa
 - 100...300 Pa
- Efficient control algorithm for fast control loops
- Analogue input and output signals to connect the setpoints and actual values for:
 - Volume flow control
 - Room pressure control
 - Room temperature control
 - Duct pressure control
- Priority control via switching contacts
- Zero point can be calibrated



ASV115CF132D

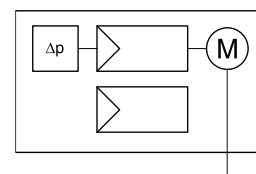
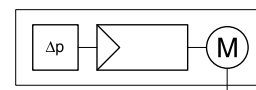

Technical data

Power supply		
	Power supply ⁴⁾	24 V~, ±20%, 50...60 Hz 24 V=, ±20%
Power consumption at nominal voltage 50/60 Hz after 30 s running time (AC/DC)	Power consumption during operation	5.7 VA/3.3 W (10 Nm)
	Power consumption when idle ⁵⁾	4.2 VA/2.1 W

¹⁾ Application support depending on hardware and software version in CASE VAV manual 7010022001

²⁾ Use of the ASV115CF132 for room pressure control only admissible for rooms with a rate of air change below 4 and leakage rate above 5% of the nominal volume flow

³⁾ Application support depending on hardware and software version in CASE VAV manual 7010022001

⁴⁾ 24 V=: Analogue inputs that are not connected are rated 0 V. The nominal torque is achieved within the specified tolerances. Terminal 02 cannot be used with 24 V= power supply.

⁵⁾ Holding torque approx. 5 Nm



Power consumption at nominal voltage 50/60 Hz after 120 s running time (AC/DC)	Power consumption during operation	4.8 VA/3 W (10 Nm)
--	------------------------------------	--------------------

Power consumption when idle ⁶⁾	4.2 VA/2.1 W
---	--------------

Parameters

Integrated damper actuator	Torque ⁷⁾	10 Nm
	Holding torque ⁸⁾	2 Nm
	Angle of rotation ⁹⁾	90°
	Running time for 90° ¹⁰⁾	30...120 s
	Admissible dimensions of damper shaft	Ø 8...16 mm, □ 6,5...12.7 mm
	Admissible damper shaft (hardness)	Max. 300 HV
	Surge-voltage resistance	500 V (EN 60730)
Δp sensor	Operating noise	< 30 dB(A)
	Measuring range Δp (gain = 1)	0...150/300 Pa
	Pressure range types D & I/E & K	
	Time constant	0.1 s
	Influence of position ¹¹⁾	Typically ±1 Pa
	Reproducibility	0.2% FS
	Zero point stability	0.2% FS (20 °C)
	Admissible positive pressure	±10 kPa
	Admissible operating pressure p _{stat} ¹²⁾	±3 kPa
	Low-pressure connections ¹³⁾	Ø i = 3.5...6 mm

Ambient conditions

Operating temperature	0...55 °C
Storage and transport temperature	-20...55 °C
Admissible humidity	< 85% rh, no condensation

Inputs/Outputs

Analogue input AI01	0...10 V (R _i = 100 kΩ)
Analogue input AI02 ¹⁴⁾	0...10 V (R _i = 70 kΩ)
Digital input DI04 ¹⁵⁾	Closed < 0.5 V, 1.3 mA, open > 2 V
Ni1000 ¹⁶⁾	0...50 °C
Resolution	0.2 °C
Digital input DI05 ¹⁷⁾	Closed < 0.5 V, 1 mA, open > 3 V
Analogue outputs ¹⁸⁾	2 × 0...10 V, load > 10 kΩ

Interfaces and communication

RS-485 not electrically isolated	115 kBaud
Protocol	SAUTER Local Communication (SLC) BACnet MSTP
Access method	Master/slave
Topology	Line

⁶⁾ Holding torque approx. 5 Nm

⁷⁾ Current-free holding torque by means of interlocking in gear unit

⁸⁾ Current-free holding torque by means of interlocking in gear unit

⁹⁾ Maximum rotation angle 102° (without end stop)

¹⁰⁾ Run-time can be set via software

¹¹⁾ Zero adjustment recommended during commissioning

¹²⁾ Short-term overload; zero adjustment of sensor is recommended

¹³⁾ Recommended hardness of tubing < 40 Sh A (e.g. silicone)

¹⁴⁾ Connection 02 can be configured as an analogue input or output using the SAUTER CASE VAV software (function only available with 24 VAC power supply)

¹⁵⁾ Digital inputs for external potential-free contacts (gold-plated recommended)

¹⁶⁾ Connection 04 can be parametrised using the CASE VAV software from version 2.0 as Ni1000 input (ASV115CF132 only from hardware index C)

¹⁷⁾ Digital inputs for external potential-free contacts (gold-plated recommended)

¹⁸⁾ Connection 02 can be configured as an analogue input or output using the SAUTER CASE VAV software (function only available with 24 VAC power supply)

Number of subscribers ¹⁹⁾	31 (32)
Length of cable without bus termination	≤ 200 m, Ø 0.5 mm
Length of cable with bus termination	≤ 500 m, Ø 0.5 mm
Bus termination	L > 200 m, 120 Ω both sides
Cable type ²⁰⁾	Twisted in pairs

Construction

Weight	0.8 kg
Fitting	Self-centring spindle adaptor
Power cable	0.5 m long, 10 × 0.32 mm ² (fixed to housing)

Standards and directives

Type of protection	IP 54 (EN 60529)
Protection class	III (EN 60730)
EMC directive 2004/108/EC	EN 61000-6-1, EN 61000-6-2 EN 61000-6-3, EN 61000-6-4
Software	A (EN 60730)
Mode of operation	Type 1 AB (EN 60730)
Conformity	Machine directive 2006/42/EC, appendix II 1.B

Overview of types

Type	Measuring range Δp
ASV115CF132D	0...150 Pa
ASV115CF132E	0...300 Pa
ASV115CF132I	0...150 Pa
ASV115CF132K	0...300 Pa

 ASV115CF132D, ASV115CF132E: Version with PVC cable

 ASV115CF132I, ASV115CF132K: Version with halogen-free cable

Accessories

Type	Description
CERTIFICAT001	Manufacturer's test certificate type M
0372300001	Torsion protection, long (230 mm)
0372301001	Spindle adaptor for squared end hollow profile (x 15 mm), pack of 10 pcs.
XAFP100F001	Flow sensor to measure the air volume in ventilation ducts
0300360001	USB connection set

Description of operation

The pressure difference generated at an orifice plate or Pitot tube is recorded by a static differential-pressure sensor and converted to a flow-linear signal. An external command signal $c_{qV,s}$ is limited by the parameterised minimum and maximum settings and compared to the actual volume flow r_{qV} .

Based on the measured control deviation, the actuator moves the damper on the VAV box until the volume flow across the measuring point reaches the required level. If there is no external command signal, the configured \dot{V}_{min} value corresponds to the command variable $c_{qV,s}$. The application and internal parameters are configured using the SAUTER CASE VAV PC software. The software allows you to configure the compact controller specifically for the application and to set the necessary parameters in bus mode.

The VAV compact controller is shipped from the factory with a default configuration. The inputs and outputs are preconfigured according to the table.

Intended use

This product is only suitable for the purpose intended by the manufacturer, as described in the "Description of operation" section.

All related product documents must also be adhered to. Changing or converting the product is not admissible.

¹⁹⁾ One subscriber is always the parametering tool, hence the maximum number of 31 connectible devices

²⁰⁾ Recommendation: Belden 3106A

Connection assignment (factory setting)



Connection	Colour coding	Function
01	Red	External command variable C_q 0...10 V (0...100% \dot{V}_{nom})
02	Black	Setpoint shift $C_{q\ ad}$ 5 V \pm 5 V (factor 0, disabled)
03	Grey	Actual value r_q 0...10 V (0...100% \dot{V}_{nom})
04	Violet	Priority control \dot{V}_{min} (actuated condition)
05	White	Priority control \dot{V}_{max} (actuated condition)

To configure the device, the design data of the VAV box must be loaded to the actuator using the SAUTER CASE VAV software. At least the following data is required for this.

Volume flow characteristics

	DN box	C factor Box	\dot{V}_n AT	\dot{V}_{nom}	\dot{V}_{max}	\dot{V}_{min}
Unit	mm	l/s - m ³ /h	l/s - m ³ /h	l/s - m ³ /h	l/s - m ³ /h	l/s - m ³ /h

Abbreviations/symbols

\dot{V}_n	Nominal volume flow	\dot{V}_n AT	Nominal volume flow, air terminal
\dot{V}_n effective	Effective nominal volume flow	\dot{V}_{nom}	Nominal volume flow in the installation
\dot{V}_{max}	Maximum volume flow setpoint	\dot{V}_{mid}	Volume flow setpoint located between \dot{V}_{max} and \dot{V}_{min}
\dot{V}_{min}	Minimum volume flow setpoint	\dot{V}_{int}	Internal volume flow setpoint
\dot{V}_{var}	Variable volume flow setpoint, for example corresponding to 0...10 V command variable	ΔP	Differential pressure at sensor (in Pa)
VAV	Variable air volume	CAV	Constant air volume
cw	Clockwise	ccw	Counter-clockwise
r_{qV}	Actual volume flow as per IEC 60050-351 (formerly Xi)	$c_{qV.s}$	Command signal of VAV controller as per IEC 60050-351 (formerly Xs)
ΔP_{max}	Maximum pressure setpoint	ΔP_{nom}	Nominal pressure in the installation
ΔP_{min}	Minimum pressure setpoint	ΔP_{mid}	Pressure setpoint located between ΔP_{max} and ΔP_{min}
ΔP_{var}	Variable pressure setpoint	ΔP_{int}	Internal pressure setpoint
r_α	Damper position feedback	$-e_{qV.s}$	Flow control deviation as per IEC 60050-351
$c_{qV.p.ad}$	Command signal shift as per IEC 60050-351 (formerly $\Delta\dot{V}$)	$c_{qV.p.2}$	Command signal of VAV controller as per IEC 60050-351 via switching contact 2 (DI05)
$c_{qV.p.1}$	Command signal of VAV controller as per IEC 60050-351 via switching contact 1 (DI04)	$c_{qP.p.2}$	Command signal of pressure controller as per IEC 60050-351 via switching contact 2 (DI05)
$c_{qP.p.1}$	Command signal of pressure controller as per IEC 60050-351 via switching contact 1 (DI04)	$-e_{qP.s}$	Differential pressure control deviation as per IEC 60050-351
$c_{T.s}$	Temperature setpoint	r_T	Temperature actual value
y	Positioning signal of valve actuator	r_P	Actual differential pressure (room or duct)
c_P	Differential pressure setpoint (room or duct)	$c_{P.p.2}$	Room pressure setpoint supplied via switching contact 2 (DI05)
FS	Full scale (maximum measuring range)		Factory setting
❄	Cooling		Heating
c/o	Changeover	DN	Nominal diameter
p	Index "p" for priority	ad	Index "ad" for additive
s	Index "s" for second priority	P	Index "P" for room pressure
q	Index "q" for quantity	T	Index "T" for temperature
		V	Index "V" for volume flow

Setting the operating volume flows

The following functions are available for operating the VAV controller.

Volume flow control setting ranges

Function	Volume flow / damper position	Maximum setting ranges	Recommended setting ranges
Damper closed	Damper fully closed		0° damper position
\dot{V}_{\min}	Minimum	$\dot{V}_{1\text{Pa}}^{21)} \dots \dot{V}_{\max}$	10...100% \dot{V}_{\max}
\dot{V}_{\max}	Maximum	$\dot{V}_{1\text{Pa}} \dots \dot{V}_{\text{nom}}$	10...100% \dot{V}_{nom}
\dot{V}_{mid}	Intermediate position	$\dot{V}_{\max} > \dot{V}_{\text{mid}} > \dot{V}_{\min}$	10...100% \dot{V}_{\max}
Damper open	Damper fully open		90° damper position
\dot{V}_{nom}	Nominal volume flow		Specific value, depending on box type, air density and application
\dot{V}_{int}	Internal setpoint	$\dot{V}_{1\text{Pa}} \dots \dot{V}_{\text{nom}}$	10...100% \dot{V}_{nom}

Pressure control setting ranges

Function	Pressure/damper position	Maximum setting ranges	Recommended setting ranges
Damper closed	Damper fully closed		0° damper position
ΔP_{\min}	Minimum	1Pa ... ΔP_{\max}	10...100% ΔP_{\max}
ΔP_{\max}	Maximum	1Pa ... ΔP_{nom}	10...100% ΔP_{nom}
ΔP_{mid}	Intermediate position	$\Delta P_{\max} > \Delta P_{\text{mid}} > \Delta P_{\min}$	10...100% ΔP_{\max}
Damper open	Damper fully open		90° damper position
ΔP_{nom}	Nominal pressure		Specific value, depending on box type, air density and application
ΔP_{int}	Internal setpoint	1 Pa ... ΔP_{nom}	10...100% ΔP_{nom}

Applications of the ASV115CF132

The following sections describe the applications for which the ASV115CF132 can be used. Detailed information on the applications described below can be found in the manual D100184112. Configuration of the application using the CASE VAV software is described in the document 7010022001.

Volume flow control

The volume flow actual value is mapped by the square root transducer integrated into the ASV 115. The volume flow setpoint is issued by the command signal at analogue input 01. Constant volume flow setpoints can be issued via the priority control to digital inputs 04 and 05, and they have priority over the volume flow setpoint at analogue input 01. The flow control deviations are corrected by the VAV controller, and the damper is adjusted until the control deviation is within the neutral zone of the VAV controller. The actual volume flow and the control deviation can be transferred via two analogue outputs.

Minimum and maximum volume flow (\dot{V}_{\min} and \dot{V}_{\max}) of the VAV controller command signal (AI01)

The \dot{V}_{\min} and \dot{V}_{\max} values, which must be configured using the software, provide lower and upper limits for the command signal $c_{qV,s}$. The values to be set for \dot{V}_{\min} and \dot{V}_{\max} are entered as percentages or absolute values. When absolute values are entered, the specific volume flow values for the installation (in %) are calculated using the equation below. When there is no external command signal, the set \dot{V}_{\min} value becomes the setpoint. The volume flow setpoint at analogue input 01 is overridden using digital inputs. The setpoint is also dependent on the logical state of the command variable and the assigned forced control.

²¹⁾ Volume flow that generates a differential pressure of 1 Pa.

Calculation of \dot{V}_{min} and \dot{V}_{max}

$$V_{min} (\%) = \left(\frac{\dot{V}_{min}}{\dot{V}_{nom}} \right) * 100\%$$

$$V_{max} (\%) = \left(\frac{\dot{V}_{max}}{\dot{V}_{nom}} \right) * 100\%$$

\dot{V}_{min} and \dot{V}_{max} in m³/h

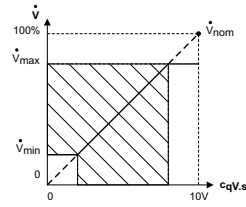

The command signal of the VAV controller $c_{qv,s}$ can be configured in various modes using the software. The ranges 0...10 V, 2...10 V and 'freely configurable' are available. The set range refers to the range 0...100% nom. Configurable forced operation is also possible via the analogue input (AI01). See the relevant section in the CASE VAV parameterisation manual 701022001.

Seepage suppression

To prevent unstable control action in the \dot{V}_{min} range, what is known as seepage is automatically suppressed. This suppression causes the damper to close when the command variable ($c_{qv,s}$) is $\leq 6\%$ of the set nominal volume flow.

Control mode resumes when the command variable ($c_{qv,s}$) is $\geq 7.8\%$ of the nominal volume flow.

Functional diagram for $c_{qv,s}$

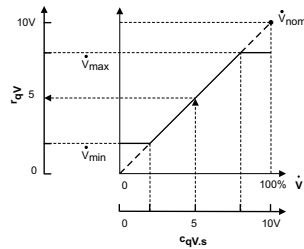

Feedback of damper position (AO02) and actual volume flow (AO03)

Three measured variables are generally available as feedback from the volume flow control loop via the SLC bus: damper position, volume flow and differential pressure. These values can be read using the SAUTER CASE VAV software in *Online Monitoring* mode.

Online Monitoring display

Damper position	° Angle of rotation	0...100% available angle of rotation
Volume flow actual value	m ³ /h	0...100% \dot{V}_{nom}
Differential pressure	Pa	0...100% P_{nom}

Functional diagram for damper position feedback r_{α}

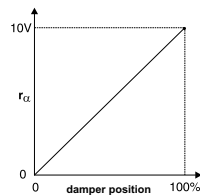

This function can be set using SAUTER CASE VAV 1.4 or higher, where one of the following applications must be selected for the device: VAV.10.001.M, VAV.20.001.M or VAV.20.001.Sxi. When configuring terminal AO02 with the damper position feedback function, it is advisable to adapt it using *Manual mode – Adapt angle of rotation*. This determines the angle between the open and closed damper positions.

In general, the actual damper position is used for the following functions:

- Indication on the BMS for monitoring the upstream pressure

- Ventilator control dependent on the individual damper positions within the installation

Additionally, the current volume flow (actual value r_{qV}) can be recorded via the VAV box at terminal AO03. The value is 0...100% of the set nominal volume flow \dot{V}_{nom} . If no specific volume flow is entered for the system, \dot{V}_{nom} corresponds to the value \dot{V}_{nAT} , set by the box manufacturer, which can usually be found on the type plate of the VAV box.

Functional diagram for actual volume flow r_{qV}

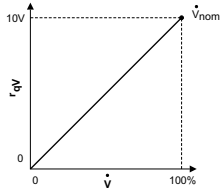

The form of the output signal r_{qV} can be configured in various modes using the SAUTER CASE VAV software. The ranges 0...10 V, 2...10 V and 'freely configurable' are available.

The actual-value signal and the command signal always refer to the set volume flow \dot{V}_{nom} .



NOTE

Actual value signals from two or more controllers may not be switched together.

In general, the actual value signal is used for the following functions:

- Indicating the volume flow on the building management system
- Master-slave application where the actual-value signal of the master controller is specified as a set-point for the slave controller

The current volume flow can be calculated from the actual value signal r_{qV} . To do this, the voltage at the output AO03 is measured and offset against the set nominal volume flow. For more information on setting the actual volume flow signal, see the CASE VAV parametrisation manual 701022001.

Flow shift $\Delta\dot{V}$ (AI02)

When a difference is required between two volume flows, for example the supply air and the return air, a parallel flow shift by a defined value $\Delta\dot{V}$ is an appropriate solution. Because the command signal $c_{qV,s}$ is always based on the nominal volume flow \dot{V}_{nom} , it makes sense to set \dot{V}_{nom} to the value of \dot{V}_{max} . This ensures that \dot{V}_{max} is always 100% volume flow. If \dot{V}_{max} is identical both as a percentage and as a quantity of the supply air in relation to the return air, an optimum balance between the volume flows is ensured.

Functional diagram for flow shift $\Delta\dot{V}$

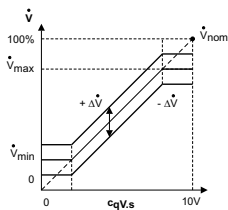

The following parameters can be set using the SAUTER CASE VAV software:

Shift factor

The setpoint shift factor is the amplification factor for defining the influence of shift. Normally it should be selected so that the influence of shift is $\leq 20\% \dot{V}_{nom}$. Recommended value: Factor 0.1 $\equiv 2\% \dot{V} / \text{volt}$ (with factory setting AI02). In addition:

- Value = 0: shift disabled | Value $\neq 0$: shift enabled

Limitation of shift

The limit is defined as a percentage of the volume flow. The maximum permitted value can be entered here.

If there is a parallel shift of the volume flow value, the set \dot{V}_{min} and \dot{V}_{max} values can be overridden.

The lower limit of the volume flow is set by the seepage suppression and the upper limit by the maxi-

mum possible installation volume flow (damper fully open). To calculate and adjust the parallel setpoint shift, see the relevant section in the CASE VAV parameterisation manual 701022001.



Note

This function is only available with a power supply of 24 V~.

Volume flow control deviation -e (AO02)

Output AO02 can be used for generating an alert if the volume flow deviates from the command variable $c_{qV,s}$. The current control deviation can be recorded as a voltage. If the setpoint is equal to the actual value, the output voltage is 5 V. If the actual value is below the setpoint, the output voltage is less than 5 V, depending on the deviation. If the actual value is higher than the setpoint, a value of more than 5 V is displayed.

Functional diagram for flow control deviation -eqV.s

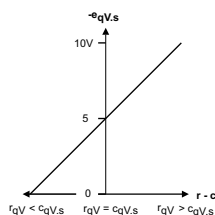

By default, the output is set in CASE VAV to a freely configurable characteristic curve with the following values.

- Start value: 0 V (-50%)
- End value: 10 V (50%)



Note

Half slope (-100%...100%, 0.05 V/% compared to 0.1 V/%) results in double the neutral zone (= green zone, no alarm) for alerting. This function is only available with a power supply of 24 VAC.

Digital inputs (DI04 & DI05)

Priority control can be implemented using the available digital inputs. Individual functions can be selected easily using the software. The digital inputs can be operated with normally-closed contacts or normally-open contacts. A mixture of NC and NO contacts can also be used. This configuration takes place using the SAUTER CASE VAV software. For more information on priority control with digital inputs and the factory settings, see the relevant section of the CASE VAV configuration manual 701022001.

Room temperature control

A second controller in the ASV 115 VAV compact controller enables it to control the room temperature. An Ni1000 sensor supplies the actual temperature value to terminal 04 of the ASV 115. The temperature setpoint can be set externally to analogue input 01. If no external signal is supplied, the internally set temperature setpoint (cTDefault) is activated. The ASV 115's integrated temperature controller can be specifically configured for the application:

- Cooling by increasing the volume of air (VAV sequence)
- Heating via reheater or radiator and cooling by increasing the volume of air (heating/VAV sequence)
- Cooling by increasing the volume of air and via re-cooler (VAV/cooling sequence)

For applications with reheaters and re-coolers, a continuous valve actuator is activated via analogue output 02.

Room temperature control can be overridden via the priority control on DI05. A defined volume flow setpoint, a damper position or the valve actuator position (open or closed) can be specified.

Temperature setpoint (AI01)

The temperature setpoint characteristic can be set using CASE VAV. Ranges 0...10 V, 2...10 V and 'freely configurable' are available for the input voltage. The default temperature setpoint range is 0...50 °C, but it can be adjusted via CASE VAV with the 'freely configurable' option.

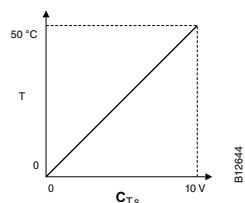

Temperature actual value (Ni1000)

The temperature is measured by an Ni1000 sensor connected to terminal 04. The measuring range of the temperature input is 0...50 °C. For more information on setting the temperature setpoint and actual value signals, as well as application-specific control parameters, see the CASE VAV parameterisation manual 0701022001.

Actuator positioning signal (AO02)

A continuous valve actuator can be activated via analogue output 02. The output signal refers to the corresponding sequence of the temperature controller and can be a 0...10 V, 2...10 V signal or freely configurable. The freely configurable characteristic of the positioning signal means that the direction of operation and the input range of the valve actuator can be taken into account. For more information on setting the valve actuator positioning signal, see the CASE VAV parametrisation manual 701022001.



Note
This function is only available with a power supply of 24 V~.

Functional diagram for positioning signal of valve actuator y

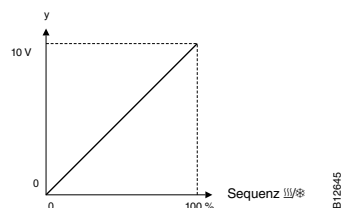

Room pressure control

A second control loop in the ASV 115 VAV compact controller enables it to control the room pressure. A differential pressure sensor with a symmetrical measuring range measures the room pressure and supplies it to analogue input 02 of the ASV 115. The room pressure actual value is compared to the differential pressure setpoint set internally in the ASV 115 in order to map the room pressure control deviation. The volume flow setpoint is adjusted until the room pressure setpoint is reached. The limitation of the volume flow setpoint shift must be set using the CASE VAV software. Two room pressure setpoints can be set in the ASV 115. The change-over between the two room pressure setpoints is performed via digital input 05.



Note
This function is only available with a power supply of 24 V~.

Functional diagram for actual room pressure value rP

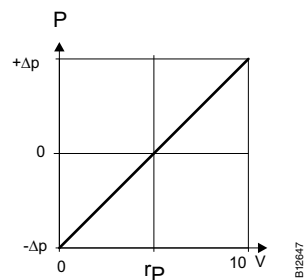

**Note:**

- ▶ The place of installation for the ASV 115 with integrated room-pressure controller must be taken into account when assigning the application in CASE VAV.
- ▶ This is because: The direction of operation of the room pressure controller differs depending on the place of installation of the ASV 115 (return air or supply air). If the ASV 115 with integrated room-pressure controller is installed on the return air, the room-pressure controller has direction of operation A (if the room-pressure control deviation increases, the volume flow setpoint shift increases). If the ASV 115 with integrated room-pressure controller is installed on the supply air, the room-pressure controller has direction of operation B (if the room-pressure control deviation increases, the volume flow setpoint shift decreases).

For more information on setting the room pressure control loop, as well as application-specific control parameters, see the CASE VAV parameterisation manual 0701022001.

Duct pressure control

The difference between the duct pressure and a reference pressure (usually atmospheric pressure) is controlled by the ASV 115. The characteristic of the internal sensor is linear to the measured differential pressure. The duct pressure setpoint can be specified externally by an analogue signal. If no external setpoint is specified, a constant duct pressure setpoint (according to the CASE VAV setting for the logical state NC) is activated. The setpoint on analogue input 01 or the constant setpoint can be overridden by digital inputs DI04 and DI05. The digital inputs can be assigned four states from eight setpoints. The duct pressure actual value and the damper position can be transferred as analogue signals to the building management system.

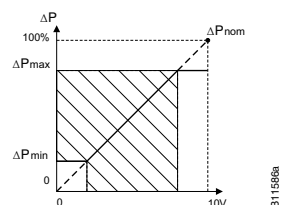
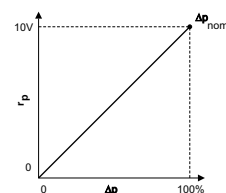
Functional diagram for differential pressure setpoint c_p **Functional diagram for differential pressure actual value r_p** **Sensor technology**

The sensor element in the VAV compact controller is a static twin-membrane sensor with PCB technology. Because of its symmetrical structure with two, principally independent, measuring cells, the sensor is compensated for installation in any position. The differential pressure acting on it is evaluated using a differential, capacitive measuring principle. Its unique design means it has very high measuring accuracy for differential pressures down to < 1 Pa, which means it is ideal for precise regulation of volume flows with a differential pressure of 1 Pa. This enables the operator to set very low \dot{V}_{\min} values for reduced mode in order to save energy.

The static measuring principle means that the sensor can also be used for measuring pumped fluids containing dust or chemicals.

Block diagram of sensor

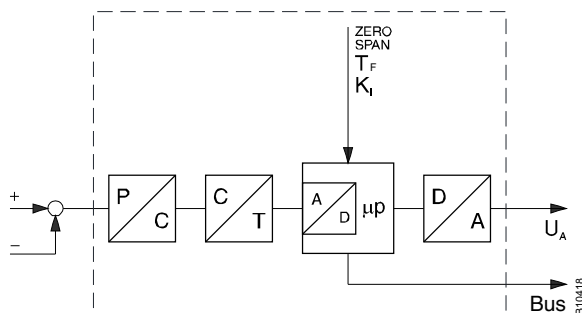

The SAUTER CASE VAV software enables users to adjust the zero point and set attenuation factors as required.

Sensor structure

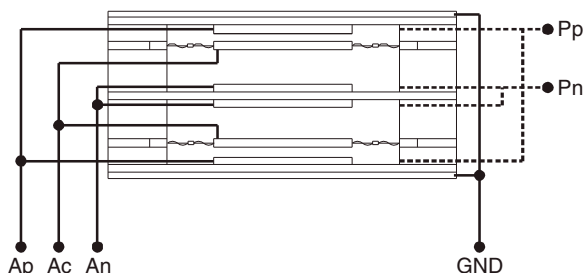

Key

Pp	Connection for higher pressure
Pn	Connection for lower pressure
Ac	Common pole of differential capacitor
Ap	Positive pole
An	Negative pole
GND	Ground

A filter time constant can be set in a continuous range of 0...5.22 s using the SAUTER CASE VAV software to stabilise the sensor measuring signal when there are highly fluctuating pressure signals. The zero point can be adjusted if necessary using calibration.

Connecting the power supply

The actuator can be operated with 24 V DC or AC. Automatic connection detection is only available when operating with AC. When operating with DC, the full nominal torque of 10 Nm is available within the specified tolerance range.

The following function in 24V= controller mode is different to AC mode on AI01 and AI02:

Functions with 24 V=

Connection	Parameterised function	Connection as-assignment	Function range 0...10 V	Function range 2...10 V	Function freely configurable
AI 01	Standard	NC ²²⁾	Vvar ²³⁾	Damper closed ²⁴⁾	
AI/AO 02	AI	Not available			
	AO	Not available			

After the power supply is connected, the working range of the damper actuator is determined automatically. To do this, the actuator moves to both end stops and determines the possible angle of rotation (factory setting). Initialisation after a power interruption can be disabled by setting a parameter in the SAUTER CASE VAV software tool.

²²⁾ NC, not connected

²³⁾ It is recommended to additionally set forced operation for LOW voltage to Vvar.

²⁴⁾ The connection is detected as LOW voltage and therefore as the factory setting for forced operation; different parameterisation leads to different behaviour.

RS-485/SLC interface function

The VAV compact controller is equipped with an RS-485 interface that is not electrically isolated. The baud rate used is 115.2 kbit/s and is a fixed setting. The SAUTER Local Communication (SLC) protocol specifies the master-slave bus access method, with a maximum of 31 devices permitted in a network segment. The 32nd user is the parametering tool. The SAUTER CASE VAV software is used to parameterise every individual device and to configure the devices within the network segment. Physical access to the bus system is either via the connection in the housing cover or via three separate wires at the end of the cable.

Functions of CASE VAV

The VAV controller can be configured using the SAUTER CASE VAV software. This software tool can be used to configure all the values required for operation by means of a convenient user interface. The connection is via a USB port on your PC or laptop, as well as via the socket on the actuator or via the RS-485 wires in the actuator cable. The set for configuring the actuator consists of: The software including installation and operating manual, fitting instructions, connection plug, cable (1.2 m long) and interface converter for the PC. The software is designed for OEM manufacturers, commissioning and service engineers, as well as experienced operators. The following functions are available:

- Simple configuration of complex applications
- Saving of device configurations as presets or backups
- Configurable unit range
- Summary screen for quick view of the main parameters
- Tree view for fast navigation to individual configuration screens
- Integrated access to system diagram and wiring diagram
- Device configuration printout
- Service function for rapid troubleshooting
- Structured user guidance
- Online monitoring of main operating parameters

Engineering and fitting notes

The actuator can be installed in any position (including a hanging position). It is plugged directly onto the damper spindle and clipped to the anti-torsion device. The self-centring spindle adapter protects the damper spindle. The damper actuator can be easily detached from the damper spindle without removing the anti-torsion device.

The angle of rotation can be limited on the device to between 0° and 90° and continuously adjusted between 5° and 80°. The limit is fixed using a set screw directly on the actuator and the limit stop on the self-centring spindle adapter. This spindle adapter is suitable for Ø 8...16 mm and □ 6.5...12.7 mm damper spindles.



Note:

- ▶ The housing must not be opened.

For feedback of the operating status it is a good idea to display the actual value signal (volume flow) on the operating station of the building management system.

Specific standards such as IEC/EN 61508, IEC/EN 61511, IEC/EN 61131-1 and -2 were not taken into account. Local requirements regarding installation, use, access, access rights, accident prevention, safety, dismantling and disposal must be observed. Furthermore, the installation standards EN 50178, 50310, 50110, 50274, 61140 and similar must be observed.

The RS-485 configuration interface in the housing cover is not designed for continuous operation. After completing the configuration, remove the parameter connector and seal the opening with the plug in order to restore ingress protection.

Outdoor installation

If installed outside of buildings, the devices must be additionally protected from the weather.

Wiring

Power supply

To ensure trouble-free operation, the following cable cross-sections and lengths are required for the 24 V power supply and the ground wire.

All devices within the same network segment must be powered by the same transformer. The power supply must be wired in a star connection with cable lengths not exceeding those in the table below ('1 device' column).

Maximum cable lengths per number of devices

Conductor cross-section	1 device ²⁵⁾	Max. 8 devices	Max. 16 devices	Max. 24 devices	Max. 32 devices
0.32 mm ²	50	6.2	3.2	2.0	1.6
0.5 mm ²	80	10.0	5.0	3.4	2.6
0.75 mm ²	120	15.0	7.6	5.0	3.8
1.00 mm ²	160	20.0	10.0	6.6	5.0
1.50 mm ²	240	30.0	15.0	10.0	7.6

Analogue signals

Analogue and digital signals are connected using the connecting cable. For trouble-free operation, the ground cable for actuators connected to each other for signal exchange must be connected to the same potential.

The maximum cable length for analogue signals mainly depends on the voltage drop on the ground wire. A signal cable with 100 Ω resistance produces a 10 mV voltage drop with a connected ASV 115. If 10 devices of type ASV 115 are connected in series to this power cable, the voltage drop is 100 mV, i.e. an error of 1%.

Ni1000 sensor

The ground of the Ni1000 sensor must be connected directly to the ground terminal (MM) of the ASV 115. The ground of the Ni1000 sensor must not be connected directly to the ground of the power supply. In a two-conductor system, the maximum admissible line resistance between the sensor and the Ni1000 input of the ASV 115 for the two conductors is a total of 5 Ω.

Connection diagram (Ni1000)

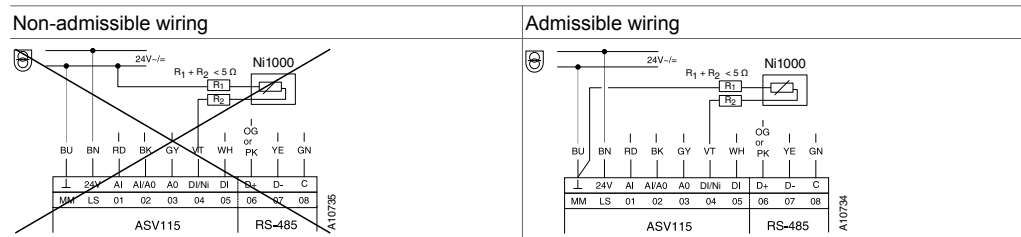

SLC bus connection

The integrated SLC bus is physically specified as an RS-485 interface. Depending on the cable length, up to 31 devices can be connected in a network segment. The C08 terminals of all controllers must be connected to each other and to the same potential. For < 200 m of wiring, neither special cables nor terminating resistors are necessary. The wiring must be implemented purely as a line topography (daisy chain). Spur lines are not permitted; if they cannot be avoided for installation engineering reasons, they may not be more than 3 m long.

²⁵⁾ Star wiring recommended.

Connection diagram (SLC bus connection)

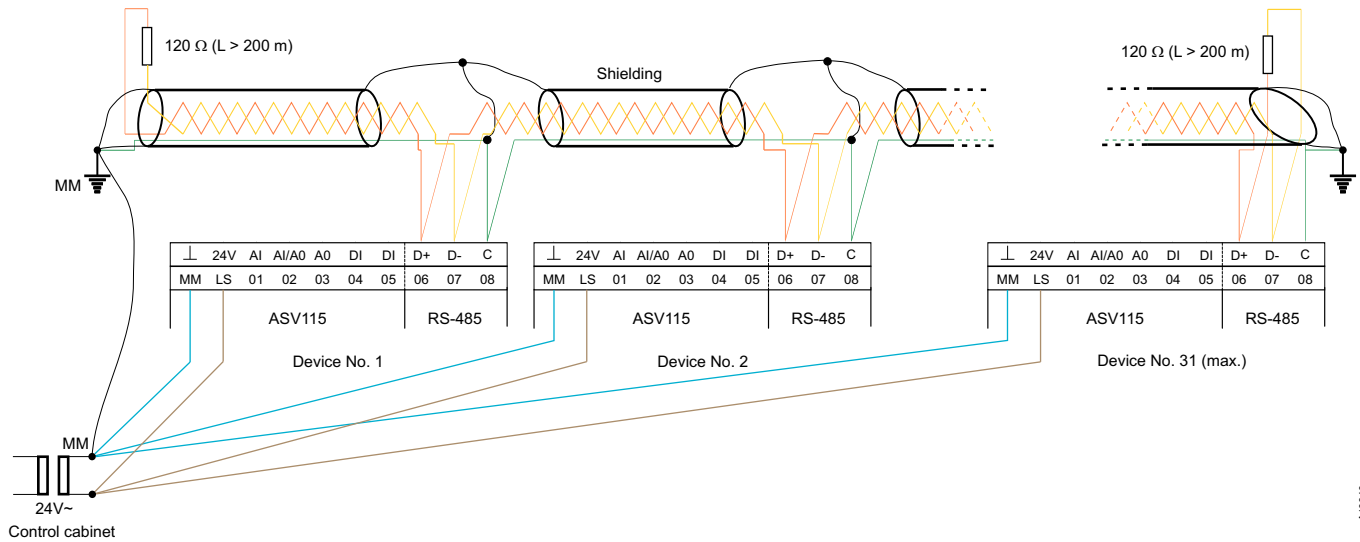

The length of the bus wiring is limited by the following parameters:

- Number of connected devices
- Cable cross-section

The following table is for twisted-pair wiring:

Twisted-pair wiring

Conductor cross-section	Number of devices	Max. cable length
0.20 mm ²	31	< 200 m
0.20 mm ²	31	200...500 m with bus termination

When using shielded cables, the shield must be earthed in the installation depending on the prevailing interference field:

- Shielding earthed at one end is suitable for protection from electrical interference (from overhead power lines, static charges etc.)
- Shielding earthed at both ends is suitable for protection from electromagnetic interference (from frequency converters, electric motors, coils etc.)

We recommend using twisted-pair wiring.

Additional technical information

The upper section of the housing with the cover and knob contains the electronic components and the sensor. The lower section of the housing contains the brushless DC motor, the maintenance-free transmission, the transmission release lever and the spindle adapter.

Any connections that are not used must be isolated and may not be grounded.



Note:

- The bus connections are sensitive to excess voltage and are not protected from the power supply. Faulty wiring can result in damage to the device.

Disposal

When disposing of the product, observe the currently applicable local laws.

More information on materials can be found in the Declaration on materials and the environment for this product.

A10640_en

Connection diagram

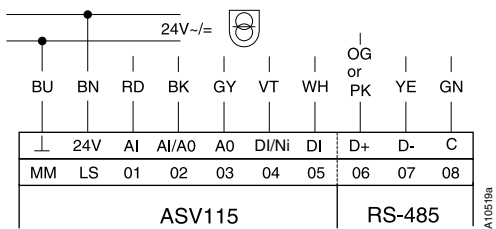

- BU = blue
- BN = brown
- RD = red
- BK = black
- GY = grey
- VT = violet
- WH = white
- OG = orange
- PK = pink
- YE = yellow
- GN = green

Block diagram (factory setting)

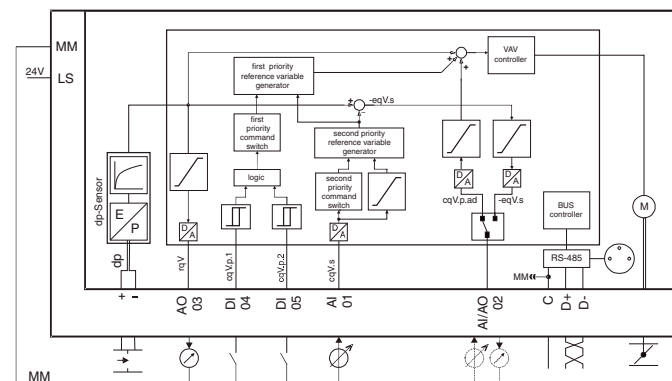

Dimension drawing

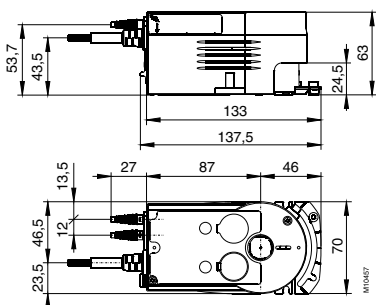

Accessories

XAFP100F001

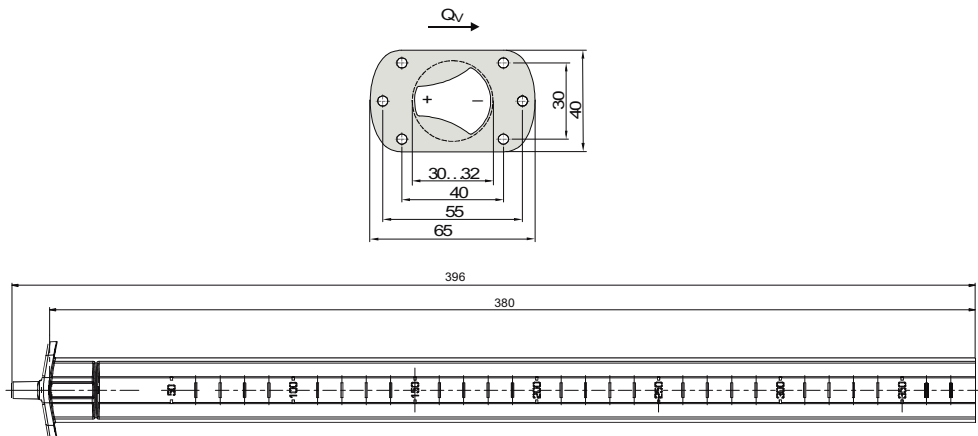

Example applications

Example 1: VAV (master-master)

Variable volume flow control with supply and return air controller in master-master configuration, regulated by a room temperature controller for rooms with high comfort and control requirements.

In master-master configurations, the supply and return air controllers (1) are both controlled by a common command signal, by default from a room temperature controller (2). The command signal shifts the volume flow values in the range from \dot{V}_{min} to \dot{V}_{max} , based on the logical states. When the settings for these limits and the system's nominal volume flow \dot{V}_{nom} are the same, i.e. the parameterised values on the supply- and return-air controllers must be identical, the volume flows can be shifted in parallel by means of a setpoint shift. This means the room pressure remains constant (balanced) even when the volume flow is variable. If the \dot{V}_{nom} , \dot{V}_{min} and \dot{V}_{max} values are parameterised differently for the supply air and return air, no defined negative or positive pressure can be produced in the room. This depends on the current volume flow.

- Setting for positive room pressure = $\dot{V}_{SA} \geq \dot{V}_{RA}$
- Setting for negative room pressure = $\dot{V}_{SA} \leq \dot{V}_{RA}$

For priority control, the digital inputs of the supply and return air controller are controlled simultaneously via switching contacts. The required parameters for \dot{V}_{min} , \dot{V}_{max} and \dot{V}_{mid} are set using the software. This method of operation is also suitable for constant volume flow control, although this function can also be implemented using a constant command signal at the setpoint input.

System diagram (example 1)

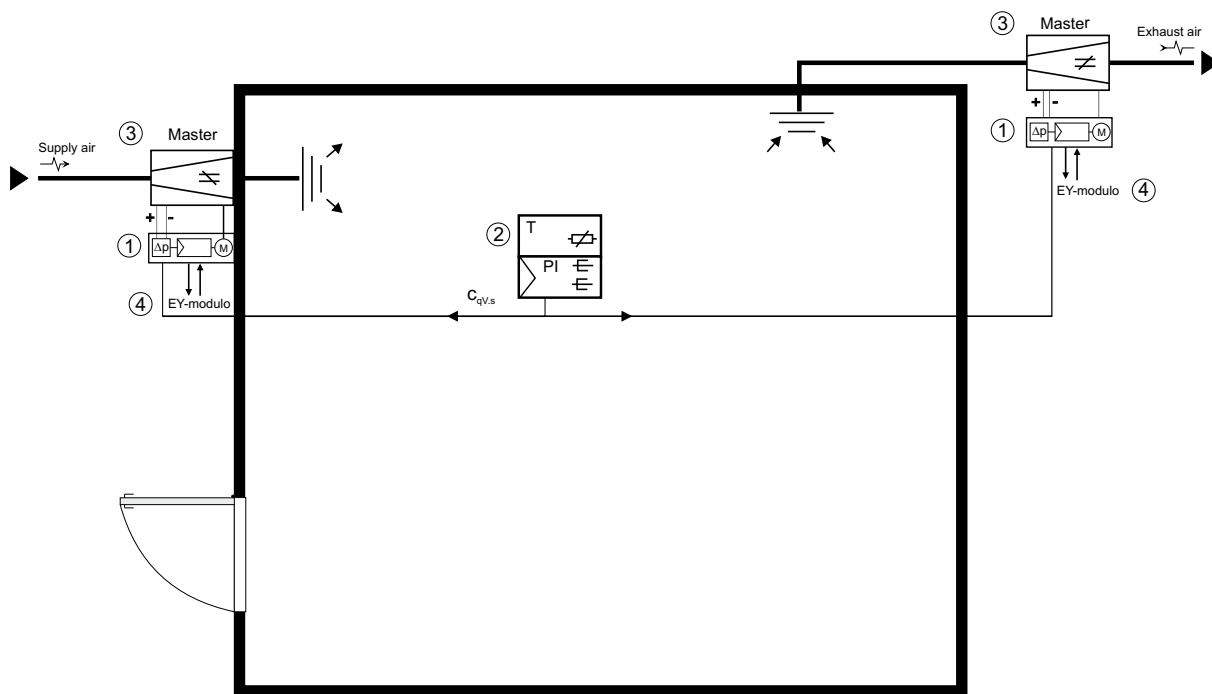

Key

1	VAV compact controller ASV115CF132
2	Room temperature controller
3	VAV box
4	Building management system: Night set-back mode/volume flow actual value

Volume flow parameters ($\dot{V}_{SA} = \dot{V}_{RA}$)

Volume flow setpoint	$c_{qv,s} = 40\% \dot{V} \in 4 \text{ V}$
Master (supply air, SA)	$\dot{V}_{min} = 20\% \dot{V}_{max} = 100\% \dot{V}_{nom} = 1000 \text{ m}^3/\text{h}$
Master (return air, RA)	$\dot{V}_{min} = 20\% \dot{V}_{max} = 100\% \dot{V}_{nom} = 1000 \text{ m}^3/\text{h}$
c-factor	100 ($\rho = 1.2 \text{ kg}/\text{m}^3$)
Actual value of the volume flow for master	$r_{qv} = 40\% \dot{V} \in 4 \text{ V} \in 400 \text{ m}^3/\text{h}$

Control diagram

$$\dot{V}_{SA} = \dot{V}_{RA}$$

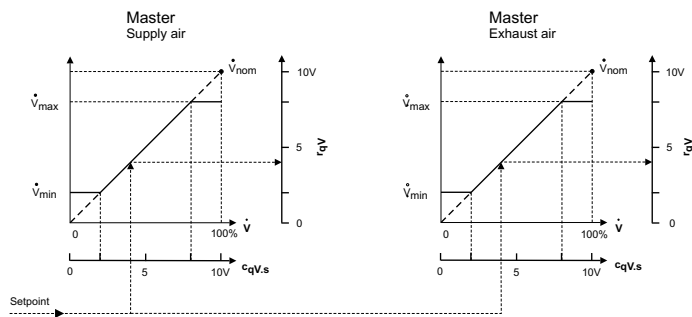

Example 2: VAV with integrated room temperature control (master-slave)

Variable volume flow control with supply and return air controller in master-slave configuration for rooms with high comfort and control requirements. The master-slave configuration allows an equal-percentage relationship between the supply air and return air volume flows.

Room temperature is controlled directly by the master controller. The temperature sensor is connected to the master controller. An external signal provides the master controller with the room temperature setpoint from either the BMS or a room operating unit. The volume flow setpoint of the master controller is specified by the room temperature controller based on the room temperature deviation within the range between min and max. In this case, the master controller can activate a reheater or a radiator valve actuator in order to provide another heating or cooling sequence.

The actual volume flow signal from the master controller is used as a command signal for the slave controller. This type of configuration is also known as schedule control. The result is that changes in the upstream pressure in the air network caused by fluctuations in the duct pressure control can be detected and transmitted directly to the slave controller. This ensures an equal-percentage relationship between the supply air and return air controller. The command signal or the actual value signal r_{qv} of the master controller can be connected to several slave controllers simultaneously.

The required operating volume flow between \dot{V}_{min} and \dot{V}_{max} is configured on the master controller. On the slave controller, \dot{V}_{min} is set to 10% and \dot{V}_{max} is set to 100%. Alternatively, \dot{V}_{min} and \dot{V}_{max} can be set so that \dot{V}_{min} (slave) < \dot{V}_{min} (master) and \dot{V}_{max} (slave) > \dot{V}_{max} (master). Note that to maintain the balance, \dot{V}_{nom} must be set to the same value for the master and slave controllers. If the \dot{V}_{nom} values are configured differently for the supply air and return air, an undesirable positive or negative pressure may be produced in the room.

- Setting for positive room pressure = $\dot{V}_{SA} \geq \dot{V}_{RA}$
- Setting for negative room pressure = $\dot{V}_{SA} \leq \dot{V}_{RA}$



Note:

With this type of room pressure generation, the resulting room pressure depends on the magnitude of \dot{V} . Defined room pressures can be achieved using room pressure controllers and the $\Delta\dot{V}$ function.

For priority control, the digital inputs of the supply and return air controller are controlled simultaneously via switching contacts. The required parameters for \dot{V}_{min} , \dot{V}_{max} and \dot{V}_{mid} are set using the software. This method of operation is still suitable for constant volume flow control, although this function can also be implemented using a constant command signal at the setpoint input.

System diagram (example 2)

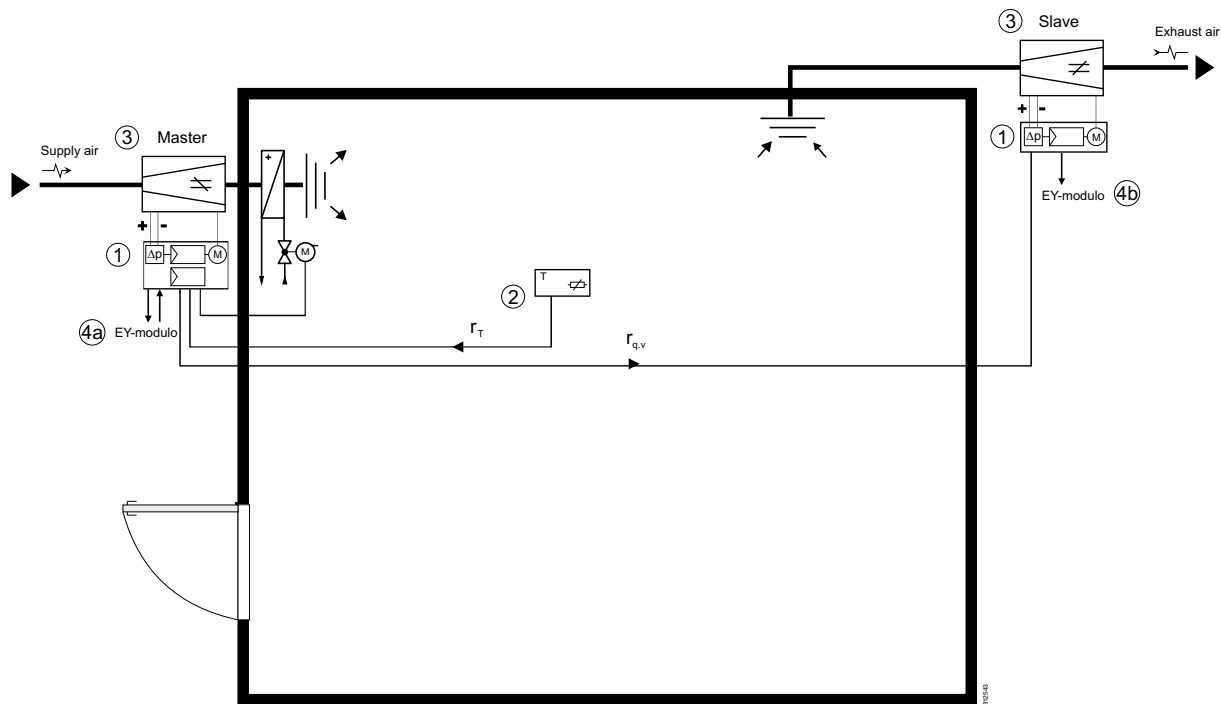

Key

1	VAV compact controller ASV115CF132
2	Room-temperature controller EGT336F101
3	VAV box
4a	Building management system: Temperature setpoint/volume flow actual value
4b	Building management system: Volume flow actual value
5	-
6	Actuator AXS215SF122

Volume flow parameters ($\dot{V}_{SA} = \dot{V}_{RA}$)

Volume flow setpoint	$c_{qV,s} = 40\% \dot{V} \equiv 4 \text{ V}$
Master (supply air, SA)	$\dot{V}_{min} = 20\% \dot{V}_{max} = 100\% \dot{V}_{nom} = 1000 \text{ m}^3/\text{h}$
Slave (return air, RA)	$\dot{V}_{min} = 10\% \dot{V}_{max} = 100\% \dot{V}_{nom} = 1000 \text{ m}^3/\text{h}$
c-factor	100 ($\rho = 1.2 \text{ kg/m}^3$)
Actual value of the volume flow for master	$r_{qV} = 40\% \dot{V} \equiv 4 \text{ V} \equiv 400 \text{ m}^3/\text{h}$

Control diagram

$\dot{V}_{SA} = \dot{V}_{RA}$

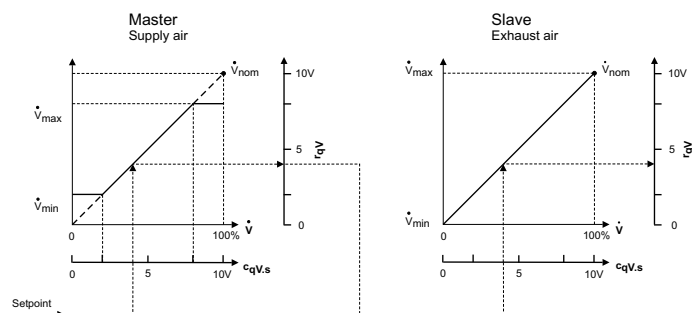

Example 3: Room pressure control (master-slave)

Because of the strict requirements for air-tightness in clean rooms and laboratories, particular attention must be paid to maintaining the pressure in these areas. This can only be done using systems with supply air and return air controllers.

The room pressure in laboratories is controlled using the supply air as standard (negative pressure control), and in clean rooms it is mainly controlled using the return air (positive pressure control). The room pressure is kept constant by cascading room pressure and volume flow controllers. Because room pressure control is integrated into the ASV 115, this cascading is performed in the VAV compact controller itself. A room pressure sensor measures the actual room pressure and supplies it to the input (AI02 rP) of the VAV controller. The room pressure setpoint is set in the ASV 115. Depending on the room-pressure control deviation, the volume flow is increased or decreased until the room-pressure setpoint is reached.

This system eliminates the need for door contacts to maintain room pressure control. Room-pressure control is always performed with respect to a reference pressure (reference pressure source, e.g. accessory 0297867001). For stable room pressure, it is essential that both the supply air and the return air have VAV controllers. A combination with the ASV115CF152 in room-pressure-controlled rooms is not permitted.

System diagram (example 3)

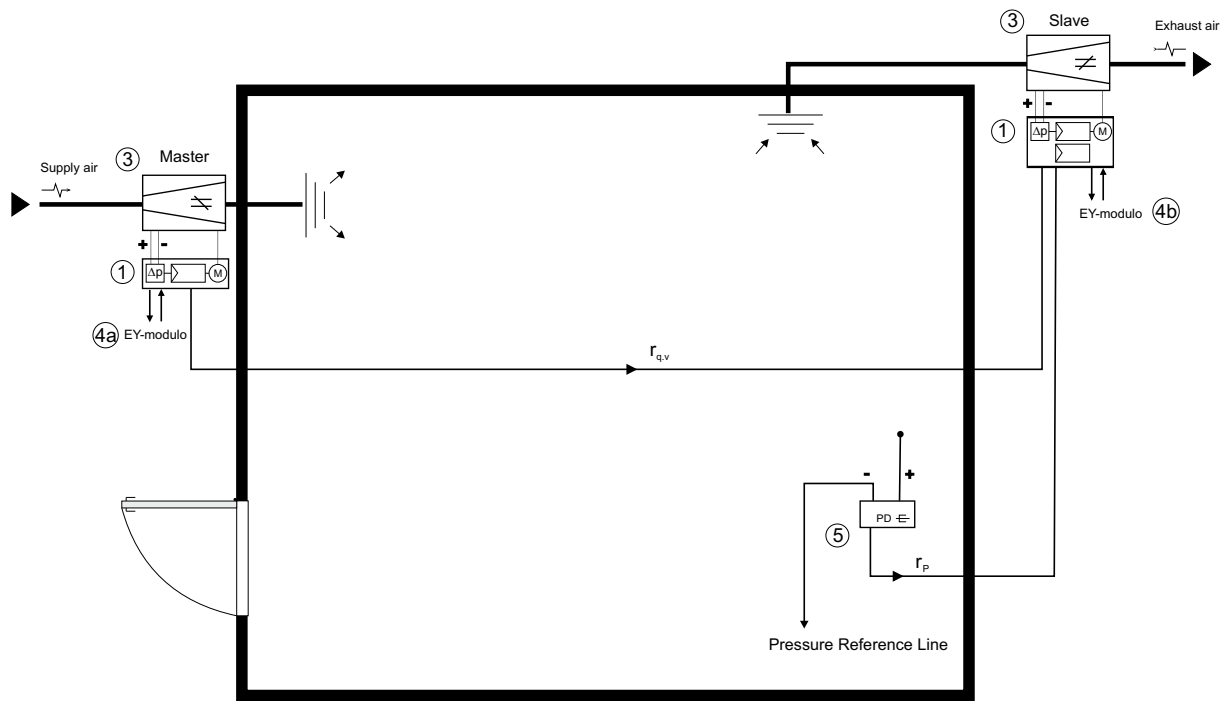

Key

1	VAV compact controller ASV115CF132
2	-
3	VAV box
4a	Building management system: Night set-back mode/volume flow actual value
4b	Building management system: Night set-back mode/room pressure setpoint change-over, actual volume flow
5	Room-pressure sensor with symmetrical measuring range, EGP100F101

Volume flow parameters ($\dot{V}_{SA} \geq \dot{V}_{RA}$)

Volume flow setpoint	$c_{qV,s} = 40\% \dot{v} \cong 4 \text{ V}$
Master (supply air, SA)	$\dot{V}_{min} = 20\% \dot{V}_{max} = 100\% \dot{V}_{nom} = 1000 \text{ m}^3/\text{h}$
Slave (return air, RA)	$\dot{V}_{min} = 20\% \dot{V}_{max} = 100\% \dot{V}_{nom} = 900 \text{ m}^3/\text{h}$
c-factor	100 ($\rho = 1.2 \text{ kg}/\text{m}^3$)
Actual value of the volume flow for master	$r_{qV} = 40\% \dot{v} \cong 4 \text{ V} \cong 400 \text{ m}^3/\text{h}$
Actual value of the volume flow for slave	$r_{qV} = 40\% \dot{v} \cong 4 \text{ V} \cong 360 \text{ m}^3/\text{h}$

Volume flow parameters ($\dot{V}_{SA} \leq \dot{V}_{RA}$)

Volume flow setpoint	$c_{qV,s} = 40\% \dot{v} \cong 4 \text{ V}$
Master (supply air, SA)	$\dot{V}_{min} = 20\% \dot{V}_{max} = 100\% \dot{V}_{nom} = 1000 \text{ m}^3/\text{h}$
Slave (return air, RA)	$\dot{V}_{min} = 10\% \dot{V}_{max} = 100\% \dot{V}_{nom} = 1100 \text{ m}^3/\text{h}$

c-factor	100 ($\rho = 1.2 \text{ kg/m}^3$)
Actual value of the volume flow for master	$r_{qV} = 40\% \dot{V} \cong 4 \text{ V} \cong 400 \text{ m}^3/\text{h}$
Actual value of the volume flow for slave	$r_{qV} = 40\% \dot{V} \cong 4 \text{ V} \cong 440 \text{ m}^3/\text{h}$

Example 4: Duct pressure control

The section pressure controller regulates the differential pressure in a duct section according to a defined setpoint. This maintains a constant upstream pressure for all VAV controllers connected to the duct section. In asymmetric or awkwardly designed air duct networks it is advisable to use a duct section pressure controller to stabilise the network. For example, the supply air and return air lines should be disconnected from the main air network on individual floors. This makes commissioning and hydronic balancing easier. Another advantage of duct section pressure control is the reduced noise levels in the duct section.

System diagram (example 4)

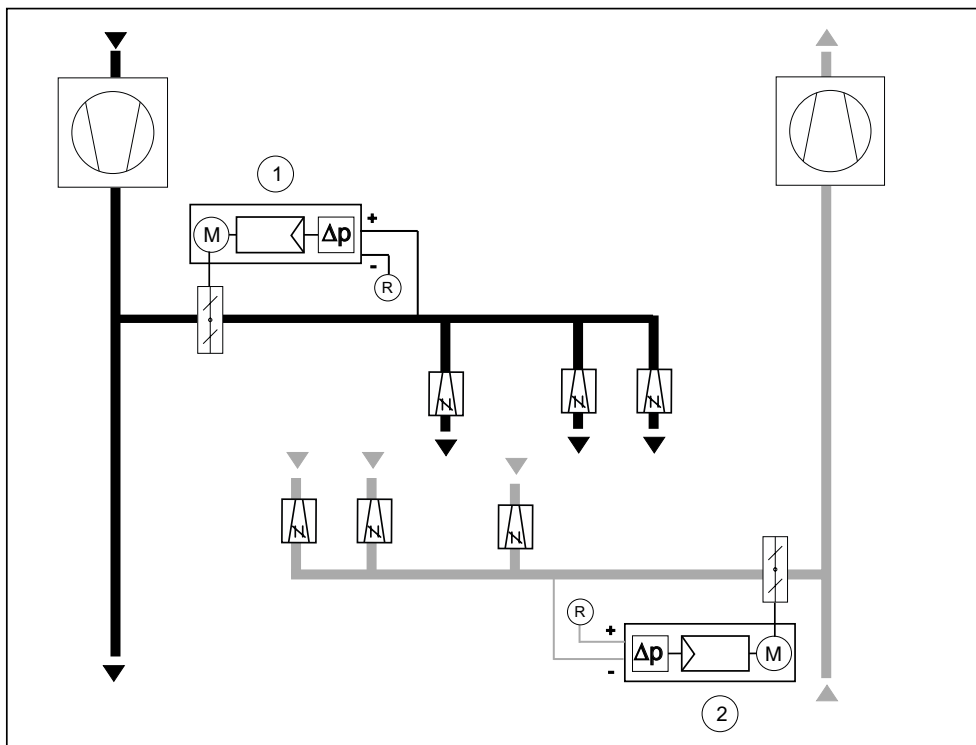

Key

- | | |
|---|---|
| 1 | Duct pressure controller, supply air, ASV115CF132 |
| 2 | Duct pressure controller, return air, ASV115CF132 |