

AVP 242...244: Pneumatic valve actuators

How energy efficiency is improved

Precise valve activation with only the slightest air requirement

Features

- Activation of 2-way and 3-way valves of the VUD/BUD, VUE/BUE, VUG/BUG, VUS/BUS and VUP series for continuous control facilities or for open/close control
- Silicone-free, therefore usable in many applications
- Rubber diaphragms with long-term stability
- The direction of operation can be reversed by fitting the unit to the bracket the opposite way round
- Stroke indicator enables the position of the actuator to be determined quickly
- Compressed-air connection with Rp 1/8" female thread
- Patented actuator–valve coupling enables the two units to be connected quickly and easily

Technical data

Parameters

Control pressure	0...1.2 bar
Maximum pressure	1.5 bar
Control span	0.6 bar

Ambient temperature

Admissible ambient temperature	−15...50 °C
Temperature at the diaphragm	Max. 70 °C

Standards and directives

Conformity	Directive 97/23/EC for pressure equipment
------------	---

Overview of types

Type	For valve with stroke	Air consumption for 100% stroke	Effective area	Weight
AVP242F001	8 mm	0.30 l _n	180 cm ²	3 kg
AVP242F021	14/20/25 mm	0.65 l _n	180 cm ²	3 kg
AVP243F021	20 mm	1.10 l _n	250 cm ²	6 kg
AVP243F031	30/40 mm	2.00 l _n	250 cm ²	6 kg
AVP244F021	20 mm	1.90 l _n	500 cm ²	12 kg
AVP244F031	30/40 mm	3.30 l _n	500 cm ²	12 kg

Assembly materials for the VUD/BUD, VUE/BUE, VUG/BUG, VUS/BUS and VUP valve series

Type of actuator	XSP31	XAP	XEP
AVP24*	297933001	297934001	297935001

Accessories

Type	Description
XSP31	Pneumatic positioner (see product data sheet)
XAP1	Auxiliary contacts (see product data sheet)
XAP2	Potentiometer unit (see product data sheet)
XEP	Electro-pneumatic converter for continuous signals (see product data sheet)
0274521000	Manual adjuster for AVP 243 and 244; weight 1.7 kg

⚠ *Electro-pneumatic converter: Of the accessories, only one positioner (XSP 31), one feedback unit (XAP) and one electro-pneumatic converter (XEP) can be fitted; if the XSP 31 and XAP are fitted, the XEP must be screwed onto the side of the fixing bracket*

⚠ *Positioner, auxiliary contact unit, potentiometer, manual adjuster: Can be used for minimum or maximum limitation of the stroke; hand wheel can be removed*

⚠ *XSP 31, XAP 1, XAP 2: Fitted at the factory to the valve/actuator combination*



AVP242F0*1



AVP243F0*1



AVP24*F0*1



Description of operation

The control pressure acts via a disc membrane against a preloaded compression spring. When the control pressure exerted on the membrane exceeds the spring pressure, the working spindle starts moving. The actuator is reversible and can be mounted on the bracket in two ways:

Function A: Normally extended (the actuator spindle is retracted as the control pressure increases).

Function E: Normally retracted (the actuator spindle is extended as the control pressure increases).

On delivery, the actuator is set up for function E.

With valves in the VUD/BUD, VUE/BUE, VUG/BUG and BUS series, (suspended plug):

Function A (assembly 0274282 000 + modification 0297938 500): Valve control passage normally open (NO)

Function E (assembly 0274282 000): Valve control passage normally closed (NC) = combination as delivered ex works.

With valves of the VUS and VUP series, (pushing plug):

Function A (assembly 0274282): Valve control passage normally closed (NC) = combination as delivered ex works.

Function E: (assembly 0000274282 000 + modification 0297938 500): Valve control passage normally open (NO)

Intended use

This product is only suitable for the purpose intended by the manufacturer, as described in the "Description of operation" section.

All related product documents must also be adhered to. Changing or converting the product is not admissible.

Engineering and fitting notes

The actuator springs are preadjusted for fitting with the valve (8 or 20 or 40 mm stroke). After assembly with the valve, the closing points must be inspected for AVP 242 according to MV 506012 or for AVP 243/244 according to MV 506013. If necessary, the spring force can be adjusted on the AVP 243/244 using the central adjusting nut. However, note that this causes a shift in the characteristic. Can be fitted in any position except suspended up to a valve medium temperature of 240 °C. For medium temperatures above 180 °C, a horizontal fitting position is recommended. The adaptor **0372336 180** for temperatures of over 130 °C to 180 °C, or **0372336 240** for temperatures of over 180 °C to 240 °C, can also be used as an extension to come out of the pipe insulation with the actuator.

Penetration of the actuator by condensate and dripping water, etc. along the spindle must be avoided. When mounting the actuator, make sure that the plug is not twisted in the valve seat (limit stop), as this can damage the sealing surface.

Pressure-stroke characteristic (with valve attached)

Characteristic not adjustable:

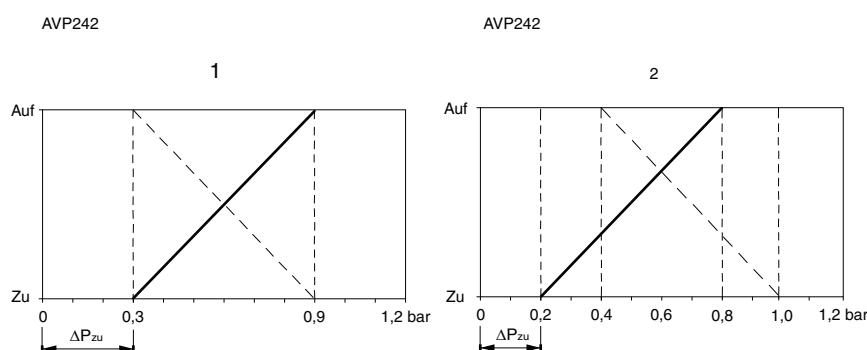

Characteristic not adjustable:

AVP243
AVP244

AVP243
AVP244

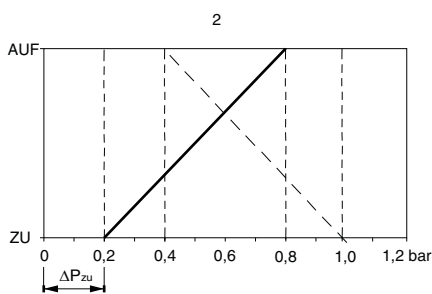
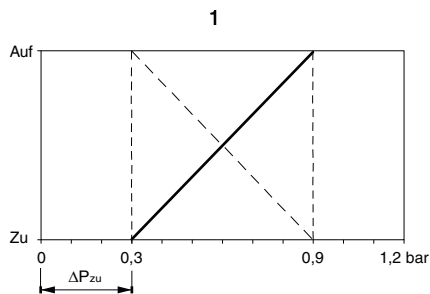

———— = normally closed (function E)
----- = normally open (function A)

Sequences possible with XSP31

For mixer valves, the characteristics refer to the upper seat (control passage).

The closing point is the control pressure at which the pressureless valve just closes.

(For 3-way valves, the upper seat = control passage).

Taking hysteresis into account, the closing points are selected so that:

- A maximum closing force is achieved for 2-way valves.
- For mixer valves, the closing force on the mixing passage is at least 2/3 of the closing force on the control passage.

Disposal

When disposing of the product, observe the currently applicable local laws.

More information on materials can be found in the Declaration on materials and the environment for this product.

Dimension drawings

AVP 242

AVP 243 / 244

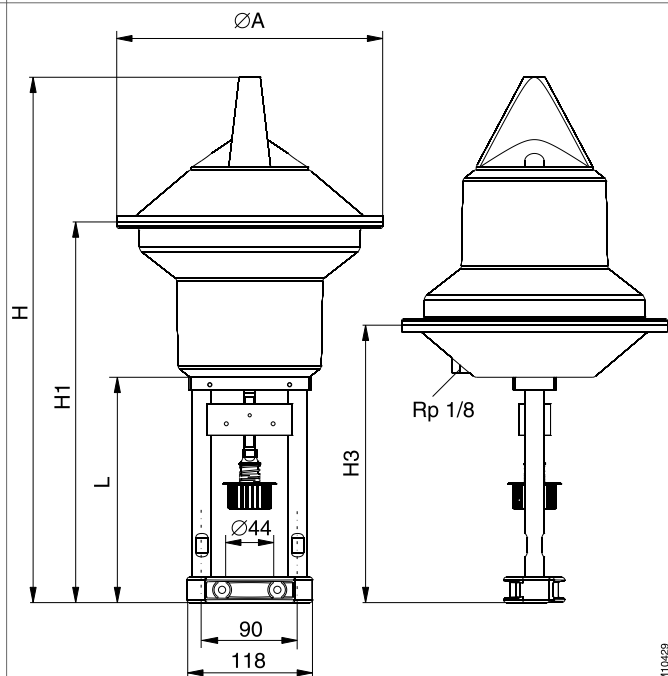
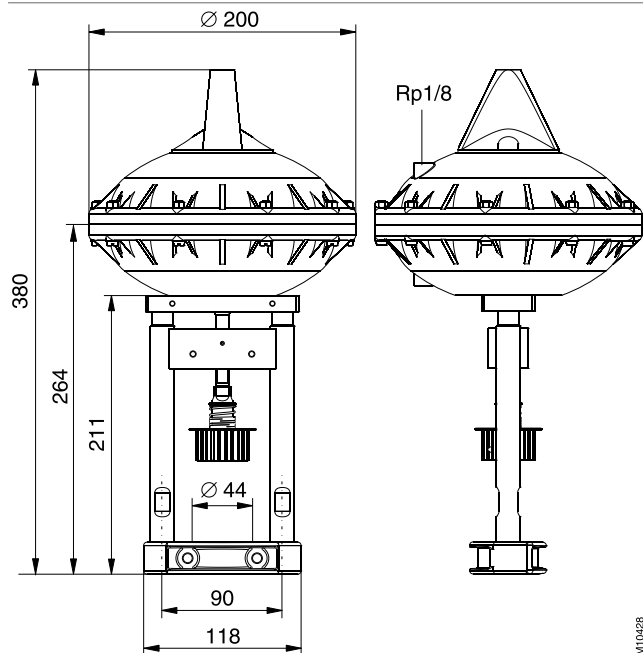

AVP...	A	H	L	H1	H3
242F001	200	377	209	262	-
242F021	200	380	211	264	-
243F021	250	497	211	357	260
243F031	250	517	232	378	281

AVP...	A	H	L	H1	H3
244F021	335	536	211	357	260
244F031	335	556	232	378	281

Manual adjuster

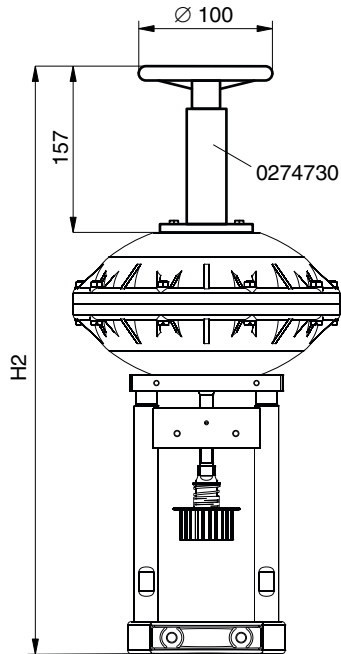

AVP ...	H2
242 F001	472
242 F021	474

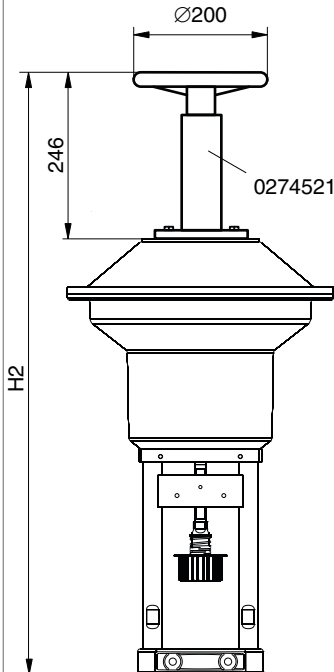

AVP ...	H2
243 F021	656
243 F031	676
244 F021	695
244 F031	715

Fitting methods for additional devices

AVP 242, XSP 31

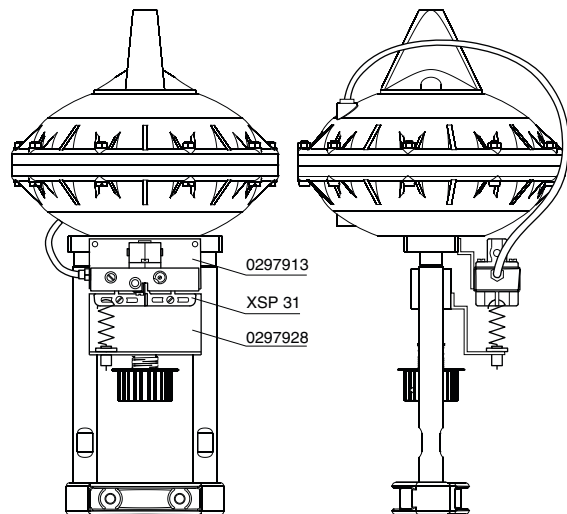

AVP 242, XEP, XSP 31

AVP 242, XEP

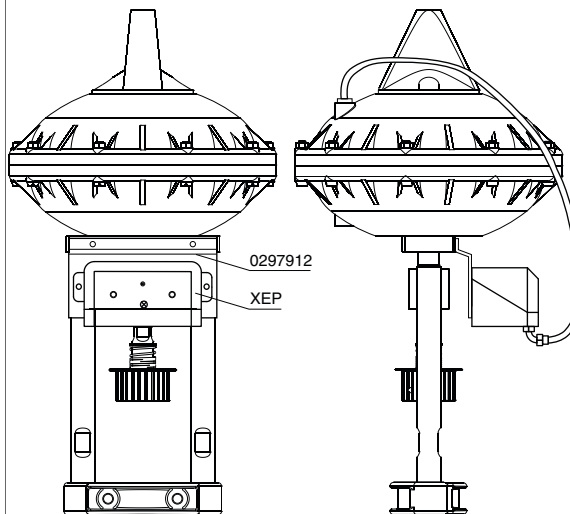

AVP 242, XAP, XSP 31

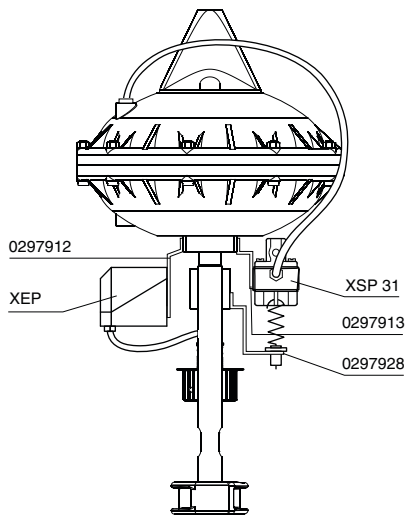

AVP 242, XAP, XEP

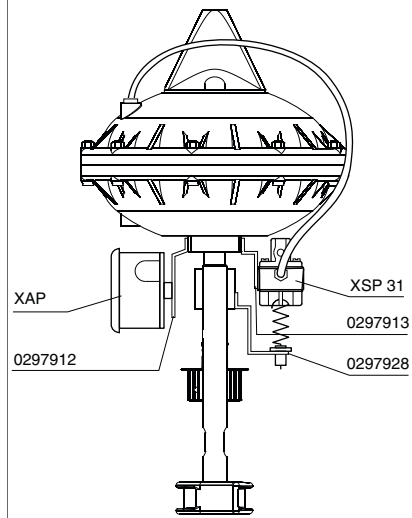

AVP 242, XAP

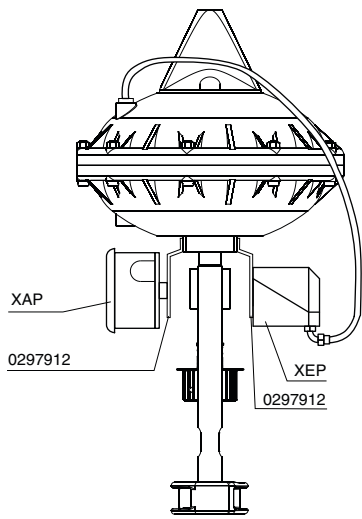

AVP 243 / 244, XSP 31

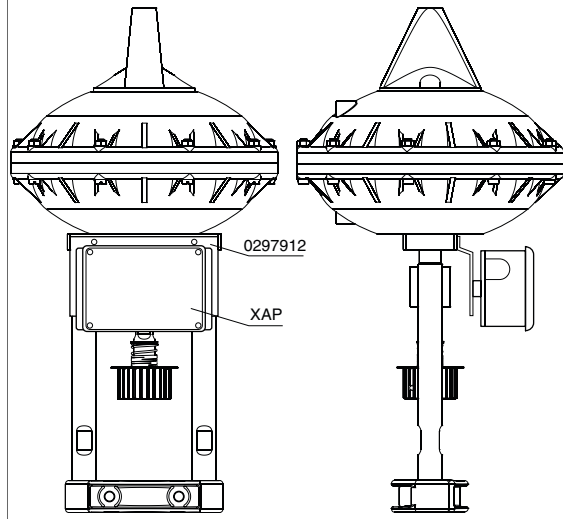

AVP 243 / 244, XEP

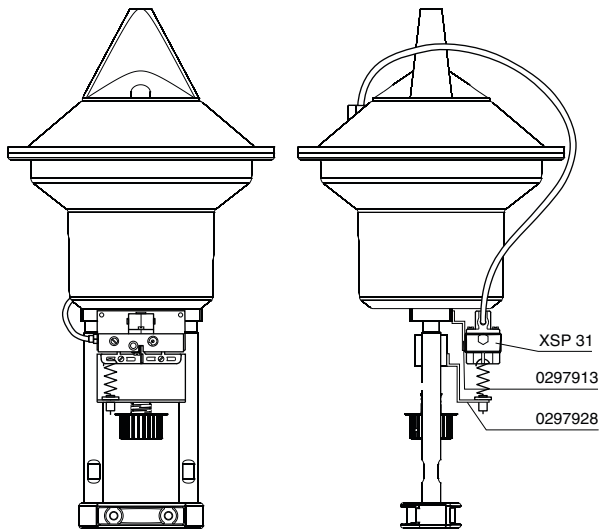

AVP 243 / 244, XEP, XSP 31

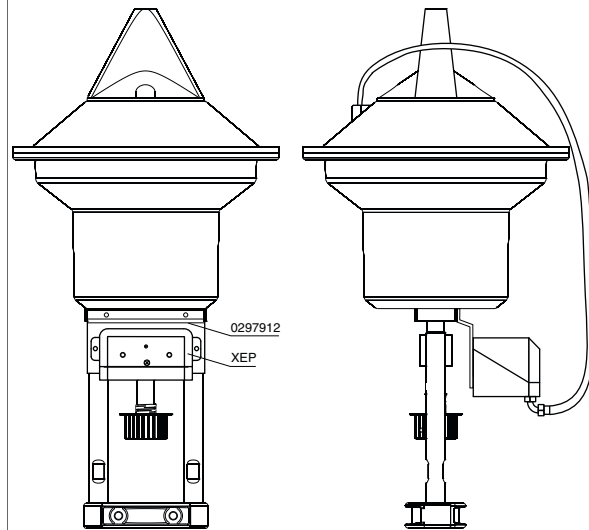

AVP243 / 244, XAP XSP31

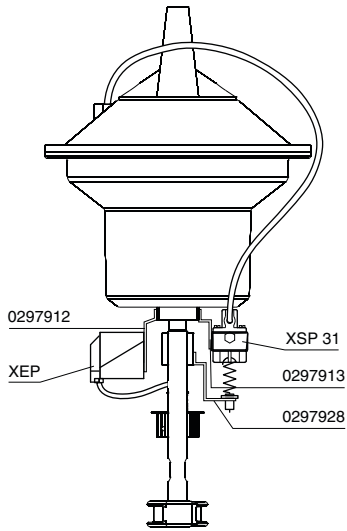

AVP 243 / 244 XAP, XEP

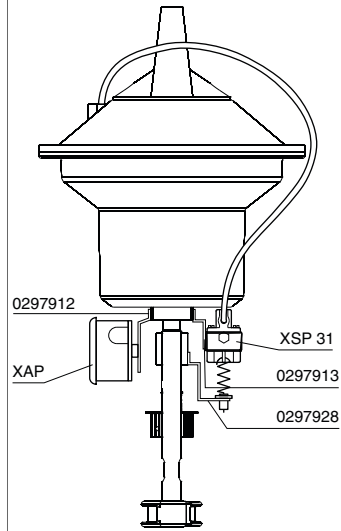

AVP 243 / 244 XAP

