

## V6R: Through valve with female thread, PN 16

### How energy efficiency is improved

Precision control with high level of reliability means efficiency.

### Areas of application

Continuous control of cold and hot water or air in closed networks <sup>1)</sup>.

Water quality as per VDI 2035. Together with actuators AVM 234SF...-5, AVF 234SF...-5 and AVN 224SF...-5 as regulating unit.

### Features

- Nominal pressure PN 16
- Nominal diameter DN15, DN25, DN40 and DN50 with reduction steps
- Basic characteristic equal percentage (F3...) or linear (F2...)
- Equal percentage characteristic or linear, adjustable with SUT actuators to linear, equal percentage or quadratic
- If the spindle is retracted, the valve is closed
- Closing procedure against or with pressure

### Technical description

- Valve with female thread as per DIN EN ISO 228-1 G
- Valve body and seat made of gun metal
- Stainless steel spindle
- Cone made of stainless steel for DN15 and brass from DN20
- Stuffing box made of brass with wiper ring and double O-ring seal in EPDM



Y07544

T04230

Type	Nominal diameter DN	k <sub>vs</sub> value m <sup>3</sup> /h	Valve plug material	Weight kg
V6R 15 F350	15	0.4	stainless steel	1.2
V6R 15 F340	15	0.63	stainless steel	1.2
V6R 15 F330	15	1	stainless steel	1.2
V6R 15 F320	15	1.6	stainless steel	1.2
V6R 15 F310	15	2.5	brass	1.2
V6R 15 F300	15	4	brass	1.2
V6R 25 F310	25	6.3	brass	1.6
V6R 25 F300	25	10	brass	1.6
V6R 40 F310	40	16	brass	3.4
V6R 40 F300	40	25	brass	3.4
V6R 50 F300	50	35	brass	4.6

Operating temperature <sup>1)</sup>	-15...130 °C	Leakage rate	≤ 0.05% of k <sub>vs</sub> value
Operating pressure	up to 120 °C 16 bar up to 130 °C 13 bar	Dimension drawings	<a href="#">5M100</a>
Valve curve	equal-percentage or linear	Fitting instructions	MV 505580
Control ratio	50 (typical)	AVM 234 / Assembly	MV 505919
Valve stroke	14 mm	AVF 234 / Assembly	MV 505920
		AVN 224 / Assembly	MV 505927

### Variants

**-F2 . . .** Valve linear curve (available from DN 15, k<sub>vs</sub> 4 m<sup>3</sup>/h only), price and pressure same as **V6R..F3..**

### Accessories

**0217268 . . .** Heating for stuffing box, 15 W; Note: 24 V = /001, 230 V = /004, MV 505498

**0360391 . . .** Union piece including asbestos-free seal, 2 pieces required.

Specify when ordering: DN 15 = /015, DN 25 = /025 etc.

DN	15	25	40	50
----	----	----	----	----

**0360421 000** Label for changing flow to 'Closes with the pressure'

**0378034 001** Valve with stuffing box, silicon-free; synthetic lubricant; max. 130 °C

<sup>1)</sup> At temperatures under 0 °C, use stuffing-box heating (accessory)

**Warranty** The technical data and pressure differences indicated here are only applicable in combination with Sauter actuators. Any warranty shall lapse if actuators from other manufacturers are used.

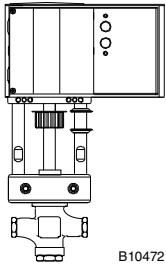

B10472

**Combination: V6R with electric drive, pushing force 2500 N**

<b>Actuator</b>	AVM 234S F132-5					
Input	2-/3-pt.; 0...10 V / 4...20 mA; 24 V / with accessories 230 V					
Running time:	28 / 56 / 84 s					
Valve	Closes against the pressure			Closes with the pressure		
	$\Delta p_{max}$	Close/off pressure		$\Delta p_{max}$	Close/off pressure	
V6R 15 F300	4	16		3	16	
V6R 25 F300	4	16		2	16	
V6R 40 F300	3	14.4		1.5	13.1	
V6R 50 F300	2	10.8		1	10.3	

**Combination: V6R with electric drive, with spring return, pushing force 2000 N**

<b>Actuator</b>	AVF 234S F132-5							
Input	2-/3-pt.; 0...10 V / 4...20 mA; 24 V / with accessories 230 V							
Running time:	28 / 56 / 84 s							
Spring return:	15 - 30 s, with F132-5 NC							
Valve	Closes against the pressure				Closes with the pressure			
	$\Delta p_{max}$	$\Delta p_s$	Close/off pressure		$\Delta p_{max}$	$\Delta p_s$	Close/off pressure	
V6R 15 F300	4	16	16		3	16	16	
V6R 25 F300	4	16	16		2	16	16	
V6R 40 F300	3	11.5	11.5		1.5	16	10.4	
V6R 50 F300	2	8.6	8.6		1	16	7.9	

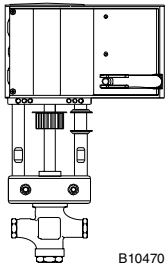

B10470

**Combination: V6R with electric drive, with safety function, pushing force 1100 N**

<b>Actuator</b>	AVN 224S F132-5							
Input	2-/3-pt.; 0...10 V / 4...20 mA; 24 V / with accessories 230 V							
Running time:	28 / 56 / 84 s							
Safe function:	15 - 30 s, with F132-5 NC							
Valve	Closes against the pressure				Closes with the pressure			
	$\Delta p_{max}$	$\Delta p_s$	Close/off pressure		$\Delta p_{max}$	$\Delta p_s$	Close/off pressure	
V6R 15 F300	4	16	16		3	16	16	
V6R 25 F300	4	16	16		2	16	16	
V6R 40 F300	3	6.3	6.3		1.5	16	5.5	
V6R 50 F300	2	4.7	4.7		1	16	4.2	

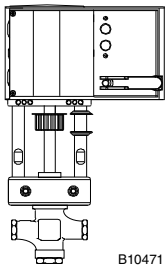

B10471

$\Delta p_{max}$ [bar]= Max. permissible pressure difference across the valve at which the drive can still firmly open and close the valve.

$\Delta p_s$  [bar]= Max. permissible pressure difference across the valve at which, in the event of a malfunction, the drive can close the valve.

Close/off pressure The pressure difference across the valve in control mode that can overcome the force of the drive. In this mode, a reduced serviceable life can be expected. Cavitation, erosion and pressure surges may damage the valve. The values stated apply only when the valve is fitted on the drive.

## Operation

Using an electric or hydraulic drive, the valve can be moved to any position.

### Closes against the pressure

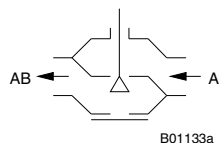

### Closes with the pressure

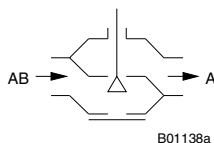

## Engineering and fitting notes

Can be fitted in any position except facing downwards (see relevant drive). When fitting the drive to the valve, care must be taken not to turn the valve plug on the two stops (seat), thus damaging the seal.

When insulating the valve, the insulation should not extend beyond the connecting clamp on the drive.

## Additional technical details

Type	$\Delta p_v$
V6R 15 F . 50	4
V6R 15 F . 40	4
V6R 15 F . 30	4
V6R 15 F . 20	4
V6R 15 F . 10	4
V6R 15 F . 00	4
V6R 25 F . 10	4
V6R 25 F . 00	4
V6R 40 F . 10	3
V6R 40 F . 00	3
V6R 50 F . 00	2

$\Delta p_v$  in bar = max. pressure difference across the valve in any stroke position, limited by the noise level and erosion (max. values without being limited by the force of the drive).

## Technical information

- Pressure and temperature specifications DIN 2401
- Flow parameters VDI/VDE 2173
- Sauter slide rule for valve sizing 7 090011 003
- Slide rule manual 7 000129 003
- Technical manual 'Regulating units': 7 000477 003  
Parameters, Notes on installation, Control,  
Pneumatic regulating units, General information

## Additional details on accessories

**0217268/...** Heating for stuffing box 15 W; housing of light metal; degree of protection IP 54; connecting cable 3 × 0.75 mm<sup>2</sup>, earth connection, 1 m in length, cable end sleeves.

## Additional details on model types

Valve body with female thread; metallic seal; flat seal of copper at the body; stuffing box with O-ring of ethylene-propylene.

## Material numbers as per DIN

	DIN material no.	DIN description
Valve body	2.1096.01	G-Cu Sn 5 Zn Pb (Rg 5)
Valve seat	2.1096.01	G-Cu Sn 5 Zn Pb (Rg 5)
Spindle	1.4305	X 12 Cr Ni S 18 8
Plug	2.0402.26	Cu Zn 40 Pb 2 F43
Plug V6R 15 F.20...F.50	1.4305	X 12 Cr Ni S 18 8
Stuffing box	2.0401.10	Cu Zn 39 Pb 3 F36

### Explanation of terms used

#### $\Delta p_v$ :

Maximum permissible pressure difference across the valve in any stroke position, limited by the noise level and erosion.

The valve as a traversed element is defined by this parameter specifically in its hydraulic behaviour. By monitoring cavitation, erosion and the noise thus produced, improvements can be achieved in both life expectancy and durability.

#### $\Delta p_{max}$ :

Maximum permissible pressure difference across the valve at which the drive can firmly open and close the valve.

Static pressure and fluidic influences are taken into account. This value helps to maintain smooth stroke action and valve sealing. In doing so, the valve's  $\Delta p_v$  value is not exceeded.

#### $\Delta p_s$ :

Maximum permissible pressure difference across the valve in the event of a malfunction (e.g. power failure) at which the drive can firmly close the valve and, if necessary, hold the full operating pressure against atmospheric pressure. Since this is a safety function with 'fast' stroke,  $\Delta p_s$  can be larger than  $\Delta p_{max}$  or, respectively,  $\Delta p_v$ . The resultant fluidic disturbances are soon overcome and play a minor role here.

On the three-way valves, the values apply only for the control passage.

#### $\Delta p_{stat}$ :

Line pressure behind the valve. This corresponds largely to the dead pressure when the pump is switched off, e.g. due to the level of liquid in the plant, an increase in pressure via the pressure store, steam pressure etc.

On valves that close with the pressure, the static pressure plus the pump pressure should be used.

Dimension drawings 5M100

V6R

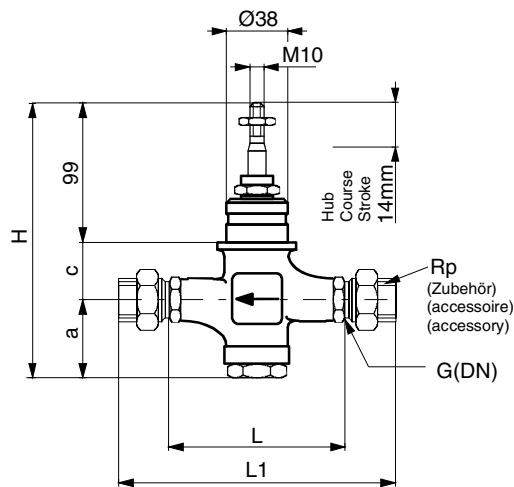

DN	a	c	H	L	L1	G	Rp
15	1/2"	56	29	184	85	159	1/2 1/2
25	1"	59	33	191	110	196	1 1
40	1 1/2"	76	47	222	150	256	1 1/2 1 1/2
50	2"	98	57	254	180	294	2 2

M361066a

AVM 2..

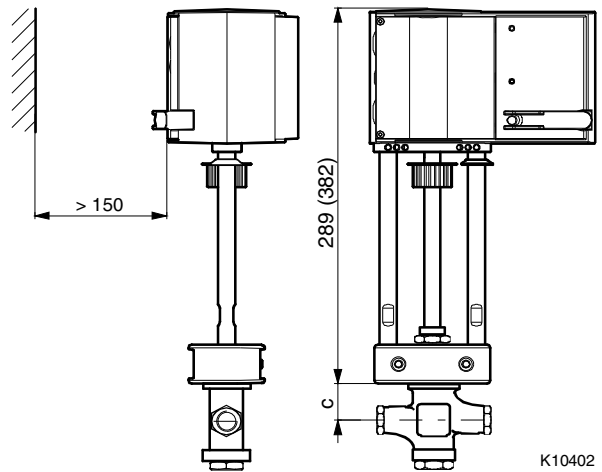

K10402

AVF 2..

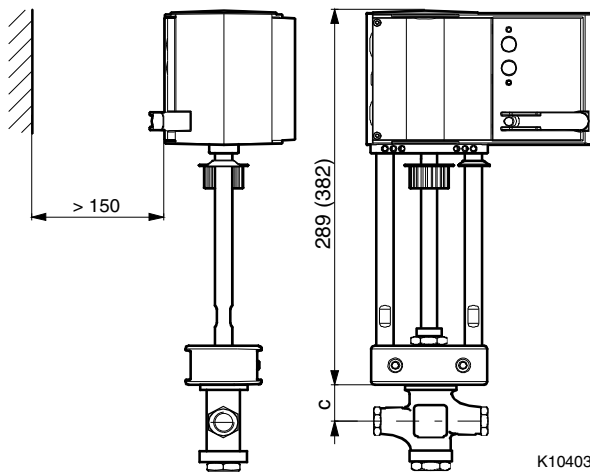

K10403

AVN 2..

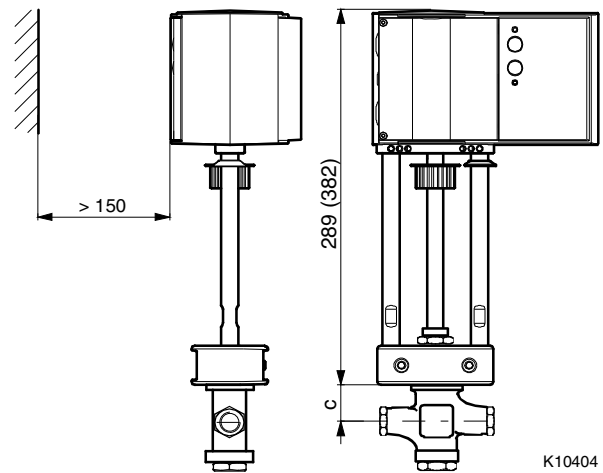

K10404

Fitting width:

Use measurement 'c' from valve dimension drawing