

EQJW 145: Heating controller for local and district heating, equitherm

How energy efficiency is improved

Convenient time programme that enables the system to be adjusted to the individual requirements of the user, and also to be switched off temporarily if required

Features

- Weather-dependent supply-temperature control and heating of drinking water
- Convenient to use with modern operating concept (turn and press) and large LCD
- Communication via Modbus/RTU or proprietary device bus
- Convenient weekly and calendar switching programmes with optimisation of switching times
- Automatic summertime/wintertime changeover
- Min./max. limitation of supply temperature and max. limitation of return temperature
- Frost-protection facility and anti-jamming function for valve and pump
- Screed curing (floor-drying function)
- Function for protecting against legionellae
- Connection of room temperature via room-temperature sensors or room operating unit
- Ni1000 inputs for the outside, supply, drinking water, return flow and room temperatures or for the room operating unit
- Relay outputs for activating control units, pumps, additional multifunctional relay output
- Pulse input for measuring and limiting flow or energy
- Manual mode
- Logbook
- Notification by text message

Technical data

Power supply		
Power supply		230 V~, ±15%, 50...60 Hz
Power consumption		Approx. 1 VA
Parameters		
Control characteristic	Supply temperature	PI control
	Temperature of drinking water	2-point
Control parameters	Proportional band	2...100 K
	Integral action time	15...1000 s
	Switching difference for drinking water	1...19 K
Temperature ranges	Normal temperature	0...40 °C
	Reduced temperature	0...40 °C
	Supply temperature	0...140 °C
	Return temperature	0...140 °C
	Outside temperature	-50...50 °C
	Domestic-hot-water temperature	20...90 °C
	Frost-protection temperature	3 °C
	Running time of valve	30...300 s
Cycle time	Running time of the valve ± 15	
Ambient conditions		
Admissible ambient temperature		0...50 °C
Admissible ambient humidity		5...95% rh, no condensation
Storage and transport temperature		-25...65 °C
Inputs/outputs		
Number of outputs		6 relays
Pump relay ¹⁾		3 × 2 A, 250 V~, cos φ > 0.5
Actuator relay ²⁾		2 × 0.5 A, 250 V~, cos φ > 0.5

¹⁾ Start-up current max. 7 A (1 s)

²⁾ Low voltage not admissible



EQJW145F001

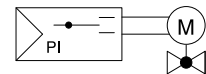
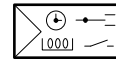

Configurable relay ³⁾	1 × 2 A, 250 V~, cos φ > 0.5
Number of inputs	1 digital, 6 analogue
Digital input	Switching current approx. 1 mA
Analogue inputs	5 Ni1000, 1 Ni1000/room control unit

Operation

Timer	Back-up power supply	Min. 24 h, typically 48 h
	Accuracy	< 1 s/d
Weekly switching programme	Number of programmes	3
	Number of switching commands	48 each
	Min. switching interval	10 min
Calendar switching programme	Number of programmes	1 (for heating circuits)
	Number of switching commands	20 each
	Min. switching interval	1 d

Interfaces and communication

Communication	Interface	RS-485, device interface (similar to RS-232)
	Protocol	Modbus, device bus (TAP)

Structural design

Weight	0.4 kg
Housing	144 × 96 mm, pure white (RAL 9010)
Housing material	Fire-retardant thermoplastic
Fitting	Wall, panel and top-hat rail
Screw terminals	For wires of up to 2.5 mm ²

Standards and directives

	Type of protection	IP 40 (EN 60529) (when fitted in panels)
	Protection class	II (IEC 60730-1)
	Software class A	EN 60730
CE conformity as per	EMC directive 2004/108/EC	EN 61000-6-1, EN 61000-6-2, EN 61000-6-3, EN 61000-6-4
	Low-voltage directive 2006/95/EC	EN 60730-1

Overview of types

Type	Properties
EQJW145F001	Heating controller for local and district heating

Accessories

Type	Description
AVF***	Motorised valve actuator (see product data sheet)
AVM***	Motorised valve actuator (see product data sheet)
AXM***	Motorised valve actuator (see product data sheet)
EGS 52/15	Room operating unit (see product data sheet)
EGT***	External temperature sensor Ni1000 (see product data sheet)
Modem	Modems tested with the EQJW*** are available on request
7010015001	Operating manual, German
7010015002	Operating manual, French
7010015003	Operating manual, English

Description of operation

The EQJW 145 heating controller performs weather-dependent controlling of the secondary supply temperature and, depending on the application, also drinking-water control. Furthermore, the primary-return temperature can be limited. Various control models are stored in the EQJW 145 for the different applications.

The temperatures (outside and supply temperatures and, depending on the application, the return, drinking water and room temperatures) are determined with precision sensors and digitalised in the controller. The microprocessor in the controller uses these values to calculate the signals for the outputs. Using the stored control model, the calculation of the output signals is based on the specified

³⁾ Start-up current max. 7 A (1 s); low voltage not admissible, potential-free contacts

setpoints, the current control offset, the set control parameters and the operating mode, along with the current actual values. These signals are processed further via switching amplifiers. The results are the ON/OFF commands of the relay outputs for the control unit(s) and the pumps.

The room is supplied with the heat required to keep the room temperature constantly at the current setpoint. If a room-temperature sensor is connected to the EQJW 145 and parameterised, the current room temperature is considered in the calculation of the setpoint for the supply temperature. For the drinking water preparation, the actual value of the drinking water temperature is compared with the setpoint. If the actual value is smaller than the setpoint, the supply temperature required for the drinking water circuit is regulated and the charge pump is switched on.

The switching programmes, which the user can adapt individually, provide an optimal comfort level at the lowest energy consumption. The temperature setpoint for the room and the drinking water can be adjusted. The operating mode can be selected easily using the rotary switch. For example, the heating or the drinking water can be switched off for a longer period, during which the frost-protection facility prevents the system from freezing.

The "temporary temperature change" function can be used to activate the party function or switch easily to another operating mode for a specific period, thus saving energy. The current operating status of the system is indicated in the LCD display, where the user can see it very easily at all times. A Modbus interface is used to communicate with the controller. It is also possible to connect multiple controllers with each other and connect a room operating unit with a digital user interface. A separate modem sends alarms via SMS if required.

Intended use

This product is only suitable for the purpose intended by the manufacturer, as described in the "Description of operation" section.

All related product documents must also be adhered to. Changing or converting the product is not admissible.

Engineering note

The equitherm EQJW 145 controller must be connected to the mains power supply all year round.

Abbreviations

T_A	Outside temperature	T_I	Initial point (foot point)
T_F	Supply temperature	T_R	Room temperature
T_{RF}	Return temperature	T_{W1}	Drinking water temperature 1 (upper)
T_{W2}	Drinking water temperature 2 (lower)	X_p	Proportional band
T_n	Integral action time	SP	SERVICE parameters
T_y	Running time of valve	V	Valve
UP	Heating pump	LP	Charge pump for drinking water
$T_{S/W}$	Heating limit	S	Slope of heating characteristic
KW	Cold water	BW	Drinking water (warm)
$T_{LO(RF)}$	Upper limit value for T_{RF}	$T_{LU(RF)}$	Lower limit value for T_{RF}
$T_{LBW(RF)}$	Limit value for T_{RF} for BW charge	$S_{L(RF)}$	Slope for limitation of T_{RF}
$T_{A(RF)}$	Value for T_A for the start of the variable part of the limitation of T_{RF}		
Symbol	Factory setting	☼	Normal mode (nominal mode based on EN 12098)
☾	Reduced mode	⏻	Off or back-up mode (with/without frost-protection facility)

Indexes		Example	
X_s	Setpoint	T_{Rs}	Room-temperature setpoint
X_i	Actual value	T_{Fi}	Actual value of the supply temperature
X_{ged}	Damped value	T_{Aged}	Damped outside temperature
max	Maximum	T_{Fsmax}	Maximum supply setpoint
min	Minimum	T_{Rsmin}	Minimum room setpoint

Additional technical data

Measuring accuracy	Better ± 0.3 K at 25 °C
Time constant for processing of measured values	Approx. 10 sec for T_A < 5 s for T_R and T_F
Neutral zone for supply temperature	± 0.5 K
Minimum pulse duration for control unit	250 ms
Follow-on time for heating pump	$2 \times T_y$
Follow-on time for LP	Can be set on the SERVICE level
Heating characteristic	Curved, without influence of extraneous heat
Damping of outside temperature	Time constant approx. 21 hours; can be (de)activated on the SERVICE level
Summertime/wintertime heating limit	ON means summer → winter OFF means winter → summer ON for $T_{aged} < T_{S/W} - 1$ K OFF for $T_{aged} > T_{S/W}$ Whereby T_A can also be used for T_{aged} . $T_{S/W}$ can be set using the SERVICE parameters
Back-up power supply	The back-up power supply is typically 48 (min. 24) hours. The EQJW 145 must be supplied with mains power for at least 4 hours.
Input for temperature sensor	Ni1000
Zero-point correction for room temperature	Up to ± 6 K possible
Zero-point correction for outside temperature	Up to ± 9 K possible
Zero-point correction for return temperature	Up to ± 10 K possible
Pulse, binary inputs	If the voltage between terminal 22 and terminal 21 (DGND) is less than 1.5 V, the contact is interpreted as closed. If the voltage is greater than 2.5 V, the contact is interpreted as open. The current across the contacts is approx. 1 mA and the no-load voltage approx. 12 V=.
Outputs	Relay with indication of switching status
Switching frequency, mechanical	> 5 million switching cycles
Maximum closing time, control unit	Twice the running time of the valve. The control unit is reactivated every 15 minutes.
Temporary temperature change	Changes to the setpoint for the room temperature in automatic mode. Change until next switching command (however, minimum 2 hours), or from 3 hours to 19 days possible. Indication of the remaining time in the display. Termination of changes possible.
Portion of extraneous heat	A continuous occurrence of extraneous heat (e.g. caused by heat loss from machines) can be considered in the heating control.
Design temperature	If the EQJW 145 is in automatic mode and T_A is lower than the set design temperature, the heating is controlled in normal mode independently of the switching programme. The design temperature is parameterised on the SERVICE level.

Special functions

Room-temperature connection	The room-temperature connection is activated on the SERVICE level. A room-temperature sensor is a prerequisite. The influence of the room-temperature connection can be adjusted on the SERVICE level. Maximum change in T_F based on room-temperature connection ± 30 K.
Frost-protection facility	The frost-protection facility is activated if the operating mode of a control loop is in the OFF mode and the frost-protection facility has been enabled on the SERVICE level. Additionally, the temperature must be below the anti-frost limit. The anti-frost limit is 3 °C for the outside temperature. The frost-protection facility is disabled when the outside temperature is above 4 °C. When the frost-protection facility is activated, a supply temperature of 10 °C is regulated for the heating circuits. If the drinking water temperature is < 5 °C, an increase to 10 °C is performed.
Anti-jamming function for pump	The anti-jamming function for the pump is enabled on the SERVICE level. Every day at midnight, a pump is activated for 60 seconds if it has not been operated for the previous 24 hours. This function is active in all operating modes apart from the manual mode.
Multifunctional relay output	One of the output relays (terminal 10) can be parameterised for a wide range of functions. This means the output can be used as a pilot clock output, as a collective alarm, for controlling a circulation pump or a 2nd charging pump, or for the forced operation of the heating pump of heating circuit 1.

Limitation of supply temperature	The maximum and minimum setpoints for the supply temperature are limited. If a setpoint is calculated for the supply temperature that is outside these limits, the limit temperature is regulated. The limit value is set on the SERvice level. In manual mode, the supply-temperature control is not active and therefore the limitation of the supply temperature does not apply. When the frost-protection facility is active, the limitation of the supply temperature is disabled.
Limitation of T_W	The maximum setpoint for T_W can be limited on the SERvice level.
Anti-legionellae function	The weekly switching programme can be used to increase T_W at regular intervals. If a higher T_W is required over a longer period independently of the switching programme, a separate switch is available for this.
Limitation of the return temperature	The maximum actual value of T_{RF} can be monitored. If the actual value of T_{RF} exceeds the limit, the setpoint for T_F is reduced. A limiting characteristic dependent on the outside temperature (fixed-value + schedule + fixed-value) can be defined for the heating circuit, and a fixed limit value for the drinking water circuit. The limiting function, or the limit value, and the influence on the setpoint for T_F are parameterised on the SERvice level.
Minimum throughflow limitation	The minimum throughflow can be limited. This is done using a pulse signal from a throughflow measuring device or the signal from an auxiliary contact of a control unit. If the function is activated, the valve is closed on the primary side and is only opened again when the setpoint of T_F is 5 K higher than the actual value.
Throughflow and power limitation	The maximum throughflow and the maximum power consumption can be limited. Limit values can be specified for the heating, the drinking water circuit and the combination of heating and drinking water circuit. If the limit value is exceeded, the supply temperature is reduced. The limit values and the level of intervention when the limits are exceeded are parameterised on the SERvice level.
Optimising the switching times	The optimising ensures that the heating is switched on and off at the optimal times in automatic mode when the system changes between reduced mode or back-up mode and normal mode. The times are selected to ensure that the room-temperature setpoint is reached at the time specified in the switching programme. At the same time, energy is saved by switching the heating on as late as possible, and turning it off as early as possible.
Manual mode	In manual mode, the relays can be activated separately for the different outputs. The settings are performed in a menu if manual mode has been enabled. The manual mode is enabled on the SERvice level. In the factory setting, manual mode is "not enabled".
Automatic cut-off	The heating controller uses its automatic cut-off to save energy wherever possible without any loss of comfort. The following options are available for switching off the heating circuit using the heating controller: a) The current operating mode for the heating circuit is OFF b) Summertime/wintertime heating limit OFF c) $T_A \geq T_{Rs}$ (when $T_A \leq T_{Rs} - 1$ K, the controller switches on again)
Floor-drying function	Section 4 of EN 1264 describes how cement screeds must be treated with operational heating before putting down floor coverings. Initially, a supply temperature of 25 °C must be maintained for 3 days. After this, the maximum supply temperature must be maintained for a further 4 days. This function is implemented in EQJW 145. Additionally, a function for screed curing has been implemented. Here the supply temperature, starting at 25 °C, is increased continuously by 5 K/day until the maximum supply temperature is reached. This is then maintained for 7 days. Afterwards, the supply temperature is decreased continuously by 5 K/day until a temperature of 25 °C is reached again. The functions are called up on the SERvice level.
Switching programmes	3 weekly switching programmes with up to 48 switching commands each and a calendar switching programme with up to 20 switching commands are available. The minimum switching interval is 10 minutes or 1 day. An operating mode from the weekly and calendar switching programmes with lower energy consumption has priority. The commands of the calendar switching programme are kept.
Multiplication of T_A	The outside temperature is determined by an EQJW 145 and passed to the other controllers via the device bus as a measured value. The parameterisation for this is performed on the communication level.
Logbook	A logbook is available. Events that occur, such as a control offset that is too big or incorrect measured values, etc., are logged. Access is protected by means of a password.
Modbus communication	You can communicate with the EQJW 145 via an RS 485 interface using the Modbus/RTU protocol. Data can be exchanged. In the process, the EQJW 145 is always used as a slave.
Notification via SMS	A modem is used to send alarm texts as SMS to a mobile phone via a provider. An interface similar to the RS 232 is used for this. The TAP protocol (Telocator Alphanumeric Protocol) is used here.

Disposal

When disposing of the product, observe the currently applicable local laws.

More information on materials can be found in the Declaration on materials and the environment for this product.

Characteristics

Heating characteristics for foot point $T_I = 20\text{ }^\circ\text{C}$

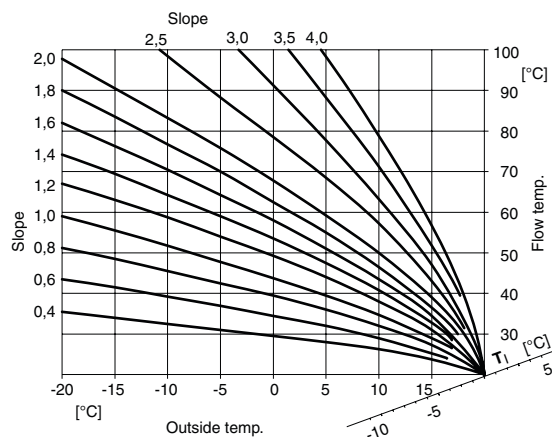

Limiting characteristic of the return temperature

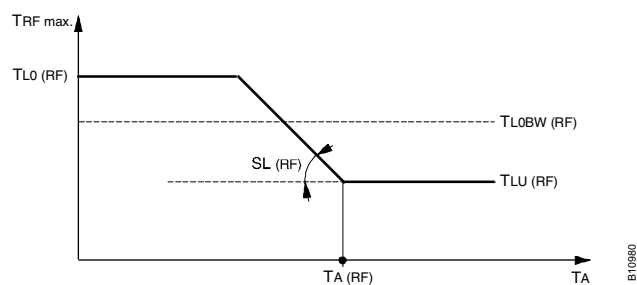

Example applications

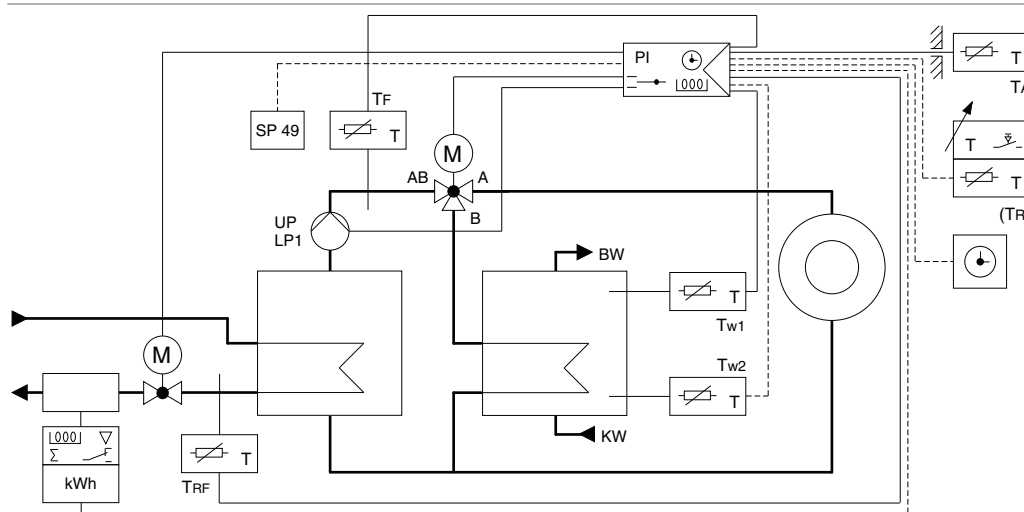

Weather-dependent supply-temperature control (secondary) in converter systems with drinking water priority switching via diverting valve.

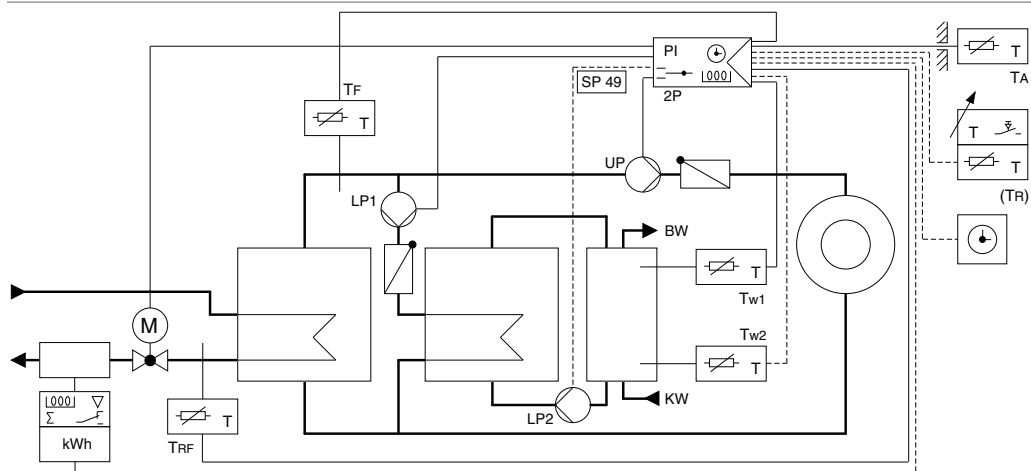

Weather-dependent supply-temperature control (secondary) in converter systems with drinking-water control by means of 2 charge pumps via additional converters (charger system).

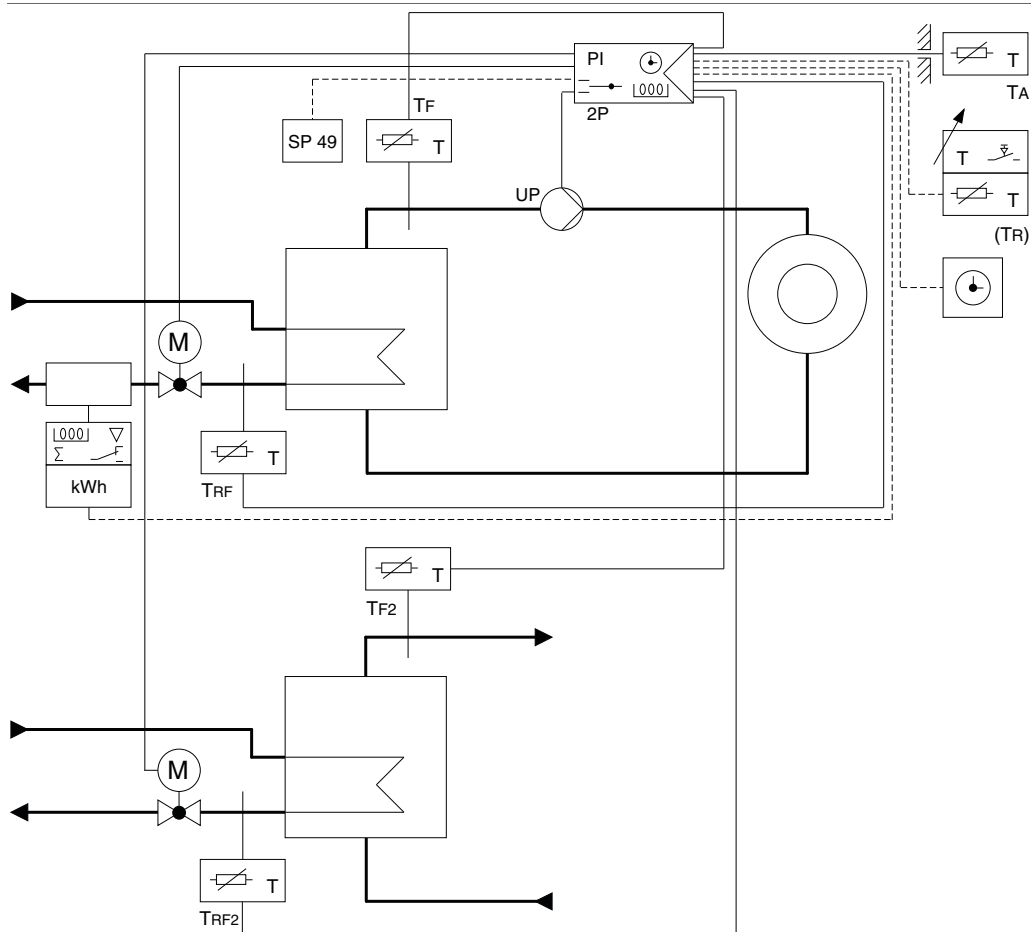

Weather-dependent supply-temperature control (secondary) and separate fixed-value control (secondary) for drinking water circuit in converter systems.

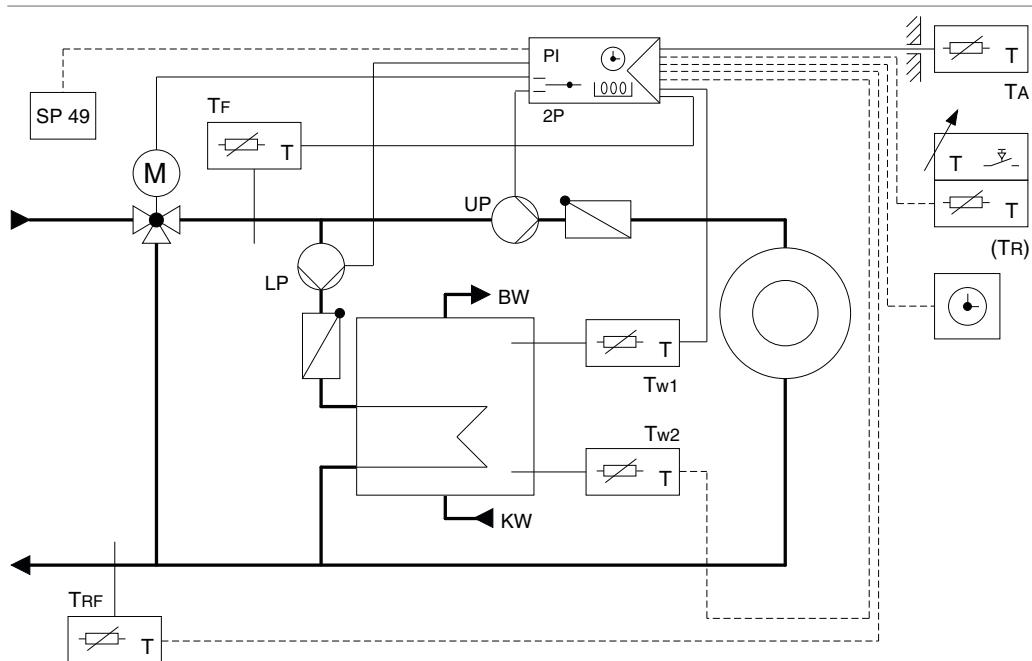

Weather-dependent supply-temperature control and drinking-water control via control valve.

Connection diagram

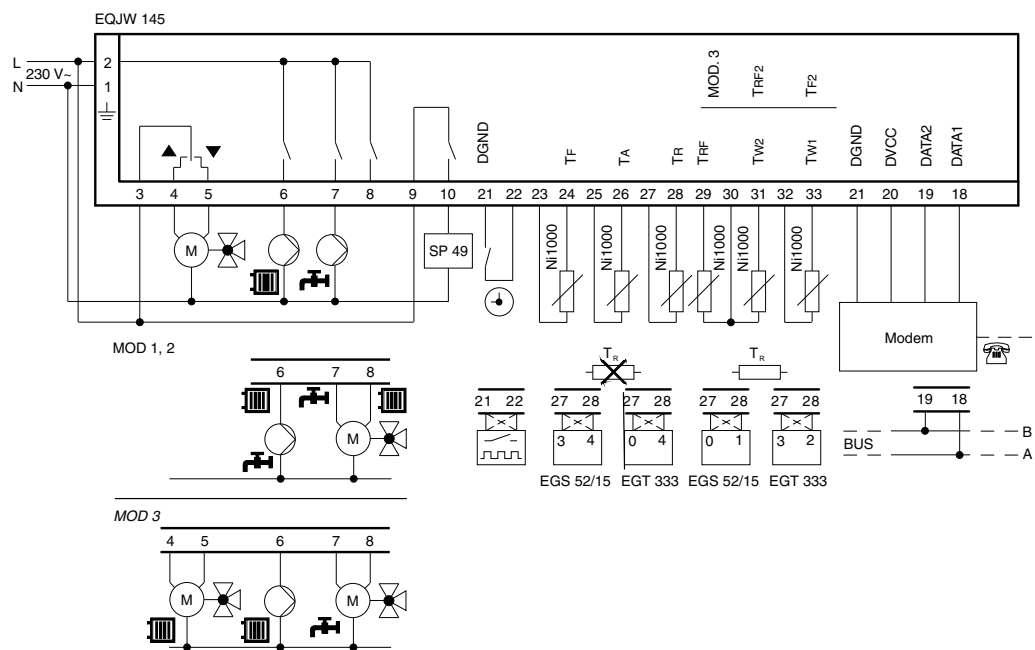

Dimension drawing

