

RDT 808, 815, 828: Universal controller with communication capability, flexotron800

How energy efficiency is improved

Highest level of flexibility with regard to adjusting the controller to the respective system and thus ensuring extremely energy-efficient operation. Additionally, option to communicate with a management level via open protocols to exchange data for the energy-efficient operation of the installation

Features

- Configurable controllers for a wide range of applications for ventilation, air-conditioning and heating
- Many functions for sequences and monitoring
- Easy to operate with large, illuminated LCD and buttons
- Menus in 20 languages
- Weekly and calendar switching programmes with summertime/wintertime change-over
- Configuration using display or PC tool
- RS485 interfaces with Modbus RTU or TCP/IP with BACnet/IP (B-ASC controller) or integrated web server



RDT828F222

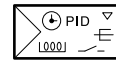

Technical data

Power supply		
Power supply		24 V~, ±15%, 50...60 Hz 21...36 V=
Dissipated power		Approx. 7.5 VA, 3.4 W Approx. 8 VA, 3.7 W TCP models
Start-up current		28 A (2 ms)
Parameters		
	Integral action time	0...600 s
	Control characteristics	P, P/PI
	P-band X_p	0...300 K
Measuring ranges		
	Normal temperature	-50...115 °C
	Pressure sensor	-500...5000 Pa
	Auxiliary controller for setpoint/actual value	-50...115 °C
	Reduced temperature	-50...115 °C
	Humidity	0...100% rh
	CO ₂	0...5000 ppm
Ambient conditions		
	Admissible ambient temperature	0...50 °C
	Admissible ambient humidity	5...95% rh, no condensation
	Storage and transport temperature	-20...70 °C
Inputs/Outputs		
	Digital inputs	Potential-free connection
	Analogue inputs	Ni1000, 0...10 V
	Input impedance	10 MΩ (for 0...10 V)
	Digital outputs	Mosfet each 2 A, 24 V=
	Analogue outputs	0...10 V=, 1 mA, protected against short circuit
	Universal inputs	Ni1000 or 0...10 V Potential-free contact
Function		
	Timer	24 h system clock Backup with battery
	Accuracy	< 2.5 s/d at 25 °C
	Back-up power supply	Min. 24 h
Weekly switching programme	Number of switching commands	4/d individual
	Min. switching interval	15 min
Calendar switching programme	Number of switching commands	24
	Min. switching interval	1 d



Timer channel	Number of switching commands	4/d individual
	Number of clock channels	5

Interfaces and communication

Interfaces	RS485 TCP/IP (option)
Protocol	Modbus RTU (Slave) BACnet/IP (B-ASC)

Construction

Weight	0.4 kg
Dimensions W x H x D	148 × 123 × 60 mm (with terminals)
Screw terminals	For wires up to 1.5 mm ²
Fitting	Top-hat rail

Standards and directives

	Type of protection	IP 20 (EN 60529)
CE conformity according to	EMC directive 2004/108/EC	EN 60730-1
	RoHS Directive 2011/65/EU	EN 50581

Overview of types

Type	Description
RDT808F012	Universal controller, 8 inputs/outputs, without LCD, RS485
RDT808F212	Universal controller, 8 inputs/outputs, with LCD, RS485
RDT815F012	Universal controller, 15 inputs/outputs, without LCD, RS485
RDT815F212	Universal controller, 15 inputs/outputs, with LCD, RS485
RDT815F022	Universal controller, 15 inputs/outputs, without LCD, TCP interface
RDT815F222	Universal controller, 15 inputs/outputs, with LCD, TCP interface
RDT815F032	Universal controller, 15 inputs/outputs, without LCD, TCP interface and RS485
RDT815F232	Universal controller, 15 inputs/outputs, with LCD, TCP interface and RS485
RDT828F012	Universal controller, 28 inputs/outputs, without LCD, RS485
RDT828F212	Universal controller, 28 inputs/outputs, with LCD, RS485
RDT828F022	Universal controller, 28 inputs/outputs, without LCD, TCP interface
RDT828F222	Universal controller, 28 inputs/outputs, with LCD, TCP interface
RDT828F032	Universal controller, 28 inputs/outputs, without LCD, TCP interface and RS485
RDT828F232	Universal controller, 28 inputs/outputs, with LCD, TCP interface and RS485

Accessories

Type	Description
XYE460F002	flexotron800 demo case
0460240001	flexotron400/800 pluggable terminal strips
0460240011	Cabinet fitting kit for flexotron800
RDB800F002	Operating unit for flexotron800 V2
EGT338F102	External setpoint adjuster, room operating unit with potentiometer and temperature sensor
0300360001	USB-RS485 converter

Additional information

Fitting instructions	P100013595
Declaration on materials and the environment	MD 46.301
Ventilation user manual	P100013556
Ventilation short manual	P100013559
Communication variables for ventilation	P100013562
Heating user manual	P100013565
Heating short manual	P100013571
Communication variables for heating	P100013568
User manual for CASE flexotron	P100012096

Description of operation

The flexotron800 devices are digital controllers for the ventilation, heating and boiler control in building automation. The controllers are freely configurable - the configuration and parameterisation are

easily performed using the integrated display with 20 languages, a separate display, or a configuration tool.

The controllers are available as models with or without a display and, depending on the model, they can be used in networks by means of a Modbus or BACnet/IP, or using the integrated web server. A separate display can be connected for all the controllers.

The flexotron800 controllers are equipped with 8, 15 or 28 inputs and outputs in order to meet the widest range of requirements.

Intended use

This product is only suitable for the purpose intended by the manufacturer, as described in the "Description of operation" section.

All related product documents must also be adhered to. Changing or converting the product is not admissible.

Engineering note

3-point activation of the valves:

- With 24 V= power supply for the controllers, the closing/opening commands are passed on to the actuators via coupling relays.
- For actuators and devices with 24 V~, the LS terminal (24V) of the RDT is connected to the MM terminal (ground in SAUTER devices) of the actuators. If additional components are connected in the system, you must be sure to avoid ground faults. If required, coupling relays are used to activate the actuators.

0...10 V sensor signals on the analogue inputs for controlling CO₂ and pressure must not fall below -0.5 V or exceed 10.5 V, as otherwise the control function is stopped.

The voltage at terminal 43 (+24 V) may only be used for activating the digital inputs.

The ground wiring for the analogue inputs and outputs and the universal inputs must be performed according to the diagram and separately in order to avoid measurement errors.

Abbreviations

SAV: Supply air fan

RAV: Return air fan

DHW: Domestic hot water

Configuration and parameterisation

The configuration and parameterisation of devices is performed via the integrated display and the buttons, or via a separate module that contains the same display and operating elements as the device.

SAUTER CASE flexotron

One variant is to perform the configuration and the settings using the CASE flexotron PC tool.

This PC-based software can be used to perform all the settings on the computer and then load them to the controller. Configurations can be saved for later use.

If required, these configuration files can simply be sent by e-mail, for example, or printed out. This configuration program provides access to all inputs and outputs, as well as to setpoints and alarms. Setpoints can be adjusted, and alarms confirmed or even blocked or deactivated.

In manual mode, the program also allows the user to change output signals directly. Another feature is the representation of actual values for up to four signals as data points in a diagram. This data can also be exported.

In the CASE flexotron program, the operating times and holiday times can also be set. The program is also used to configure the settings for the communication via TCP/IP.

For the ventilation and heating/boiler control, you must carry out separate installations of the CASE flexotron - CASE flexotron ventilation and CASE flexotron heating. However, the two programs are very similar as regards how they are used and their functionality.

Display

The display is illuminated and has four lines of 20 characters each. The illumination is activated when the buttons are pressed.

The user can select from 20 languages for displaying the menus and the parameter names.

Inputs/Outputs

Type	Analogue inputs	Digital inputs	Universal inputs	Analogue out-puts	Digital outputs	Display	RS485	TCP
RDT808F012	2	3	-	1	2	-	•	-
RDT808F212	2	3	-	1	2	•	•	-
RDT815F012	4	4	-	3	4	-	•	-
RDT815F212	4	4	-	3	4	•	•	-
RDT815F022	4	4	-	3	4	-	-	•
RDT815F222	4	4	-	3	4	•	-	•
RDT815F032	4	4	-	3	4	-	•	•
RDT815F232	4	4	-	3	4	•	•	•
RDT828F012	4	8	4	5	7	-	•	-
RDT828F212	4	8	4	5	7	•	•	-
RDT828F022	4	8	4	5	7	-	-	•
RDT828F222	4	8	4	5	7	•	-	•
RDT828F032	4	8	4	5	7	-	•	•
RDT828F232	4	8	4	5	7	•	•	•

Control models

The flexotron800 controllers have two operating modes: ventilation and heating. The heating mode also includes various functions for the domestic-hot-water preparation and the boiler control. Depending on the devices selected, they have the following control models:

Ventilation control:

- Supply-air control
- Outside-temperature-based supply-air control
- Room supply-air cascade control
- Return-air/supply-air cascade control
- Outside-temperature-based switching between room supply-air cascade control and supply-air control
- Outside-temperature-based switching between return-air/supply-air cascade control and supply-air control
- Room supply-air cascade control based on outside temperature
- Return-air/supply-air cascade control based on outside temperature

Heating:

Heating control:

- Heating control for 1...3 heating circuits
- Cooling control for 1 cooling circuit
- Domestic-hot-water control, 1...2 systems
- Control for storage tank pump

Boiler control:

- Boiler control circuit with 1...4 boilers, each controlled with 1- or 2-level or modulating burners.

Summary of functions for all control models (ventilation, heating)

Communication

All flexotron800 controllers have at least one interface. Versions with RS485: This can be used to communicate with the devices via Modbus RTU. Along with the integration into a Modbus RTU network as a slave, the RS485 also provides the option to incorporate additional flexotron800 controllers as extension units, or to control prepared frequency converters via Modbus.

Versions with a TCP/IP interface: These devices can be incorporated into a network via BACnet/IP or the integrated web server. This interface can also be set up and configured using the configuration tool.

Versions with RS485 and TCP/IP interfaces: These devices allow a combination of the options listed, via the RS485 or TCP interface. The configuration can be performed via both interfaces.

The devices with a TCP interface are listed as BACnet B-ASC controllers.

Alarm handling

If there is an alarm, the alarm LED flashes on the front of devices with a display. The LED keeps flashing as long as there are unacknowledged alarms. Alarms are logged in the alarm list, which shows the last 40 alarms.

Three classes of alarms are available, two of which have to be acknowledged and reset before operation can continue.

Time programme

Flexotron800 controllers have a year function in which weekly plans for a whole year, including days off and holidays, can be set. The switch between summertime and wintertime is performed automatically.

Every day has up to two separate periods of use. For two-level ventilators and pressure-controlled ventilators, daily schedules are available for two levels, each with up to two periods of use.

Timer outputs

Up to 5 digital outputs can be used as time-controlled outputs. Each of the 5 clock channels has a separate schedule with two periods of use for each weekday. These can be used to control lighting, doors, etc.

Access rights

The devices have various access rights, which are activated using passwords:

- Admin – for all read/write access for all settings and parameters in all menus.
- Service – access to all menus apart from the configuration of the inputs/outputs and the system.
- User – read access for all settings and parameters and write access for settings and parameters apart from the configuration.

Manual/automatic mode

To check individual functions of the controller, the configurable outputs can be adjusted manually. Controller and analogue outputs can be set to values between 0% and 100%, and digital outputs to ON or OFF.

Manual/automatic mode

To check individual functions of the controller, the configurable outputs can be adjusted manually. Controller and analogue outputs can be set to values between 0% and 100%, and digital outputs to ON or OFF.

Summary of functions for ventilation

Temperature control

The temperature control can be performed with sequences for heating/cooling/heat recovery dampers. Here the individual elements for various model variants can be configured:

- Heater: water, electric
- Heat recovery: plate heat exchanger, rotation heat exchanger, circuit compound system, mixed-air dampers. The heat recovery can also be controlled in an outside temperature function.
- Cooler: water

The control signals of a sequence can be divided between two different outputs.

Extra sequences: These are two additional independent sequences for the temperature control.

In the sequence setting the user can define how and in which area the controller output affects the existing sequences.

The temperature control for heaters or coolers can also be controlled in levels. Up to four heater and three cooler levels can be configured.

Frost-protection facility

If the controller is set to OFF or manual control and the outside temperature is below the set value, a minimum supply temperature is maintained and the pump is in operation.

Back-up mode

For cascade control with an activated room-temperature sensor, the back-up mode is activated for heating and cooling. The minimum running time for back-up mode can be set, along with the switching-on and switching-off temperature.

Free cooling

This function is used in the summer to cool the building with the cold night air. The starting and stopping values and the running time can be set.

Cold recovery

If the return-air temperature is lower than the outside temperature, the cold recovery can be activated.

Enthalpy control

If the enthalpy value of the outside air is greater than the enthalpy value of the inside air, the mix damper signal to increase the recirculated air proportion can be disabled. This function is not active for free cooling.

External setpoint

It is possible to use an external setpoint transmitter with Ni1000 characteristic for the temperature setpoint. Minimum and maximum values can be set.

Humidity control

The humidity control can be configured as

- Humidification

- Dehumidification
- Humidification/dehumidification

Two humidity sensors can be connected: one sensor for the room humidity and one sensor for the channel humidity for the maximum limitation. The control is by means of a PI-controller and controls the humidifier via an analogue signal or a digital signal.

Ventilator control

The control of the ventilators can be configured on one or two levels, or via frequency converters. When frequency converters are used, the following options are available:

- Constant pressure: The pressure signal of a pressure transmitter is kept constant by means of the frequency-controlled ventilator.
- Constant volume flow: The volume flow is calculated using a signal from the pressure transmitter and kept constant by means of the frequency-controlled ventilator.
- Output manually set to defined values: The output signal of the frequency converter is set to a fixed value or is set using the measured value of a CO₂/VOC sensor for demand-led ventilation.
- External control signal: Direct control using external 0...10V control signals for incorporation in VAV systems.
- SAV frequency control with RAV slave: The output of the RAV follows the output of the SAV.
- RAV frequency control with SAV as slave: The output of the SAV follows the output of the RAV.
- SAV frequency control with volume flow-controlled RAV: Frequency- and pressure-controlled SAV. The volume flow of the RAV is controlled by means of the volume flow of the SAV.
- RAV frequency control with volume flow-controlled SAV: frequency- and pressure-controlled RAV. The volume flow of the SAV is controlled by means of the volume flow of the RAV.

Pump control

Digital inputs and outputs can be configured for the pump control: heaters, heat control, coolers. For all pumps, operating or fault indicators can be connected by means of a digital input, and an anti-jamming function can also be configured. The switch-off delay can also be set.

Damper control

The following control options can be configured:

- Shut-off dampers
- Exhaust-air damper
- Return-air damper control
- Fire-protection dampers, and activating the test run of the fire-protection dampers

The shut-off damper can be controlled individually or together with the exhaust-air/return-air dampers; it is also possible to set a minimum position for the dampers during operation.

Recirculated air control to distribute the room air using the SAV can also be configured, with or without temperature control.

A minimum position for the dampers can be set.

Changeover

The changeover function enables the user to change between heating and cooling control in 2-pipe systems. A digital input signal is used to change over the function.

Additional control loop

The controller has a separate, additional control loop with a PI characteristic, with both a sensor input and an analogue and digital output signal for controlling, for example, a post-treatment device.

Fire alarm

In the fire alarm function, the controller has various options. It can be activated via a digital input; the ventilators can be switched off individually or collectively, as required; the direction of operation of the fire protection damper can be set.

Blocking the automatic restart when the power is restored

The restart after a power failure can be blocked. The standard setting is set to automatic start.

Summary of functions for heating (heating/cooling/domestic hot water/boiler control)

The flexotron800 controller can be used for heating, cooling and domestic hot water control. Boiler control functions can also be used simultaneously. However, the user must consider the available number of inputs and outputs for each model.

Heating circuits:

Between 1 and 3 heating circuits can be controlled by the flexotron800 controller. The controllers are PI-controllers with an adjustable P-band and I-time.

The controllers have individual heating characteristics and room temperature sensors can be used to adapt the characteristics. The heating systems have individually adjustable minimum and maximum temperatures for the supply and return.

The valves are actuated by 3-point or continuous 0...10 V signals.

Pump control

Each system can have one or two pumps. Twin pumps operate alternately by automatically switching over once a week and starting the reserve pump automatically if the active pump fails. The pump can be configured to stop depending on the outside temperature.

Frost-protection facility

If the controller is set to OFF or manual control and the outside temperature is below the set value, a minimum supply temperature is maintained and the pump is in operation.

Corrections and limitations

A wind sensor can be connected which can offset the influence of wind using a setpoint shift.

Building inertia can be set in order to adapt to the effect of the outside temperature.

A digital input can temporarily limit the power to the heating circuits. To do this, the setpoint is lowered.

Night reduction

The night reduction is specified by the room temperature. The controller has individual time programmes for each heating circuit with two periods of use per day.

Switch-on optimisation

This function automatically calculates the end of night reduction. This ensures that the desired temperature is reached at the starting time (comfort) set in the timer channel. A room temperature sensor is required to use this function.

Cooling circuit:

The controller has a cooling circuit which can also be used for dew point control.

The setpoint is either fixed, outside temperature-led or demand-led.

The valve is actuated by 3-point or continuous 0...10 V signals. It is possible to set an upper limit for the supply temperature, and both upper and lower limits for the return temperature.

Dew point control

Cooling control has a dew point control for the coolant circuit. This control operates with the aid of a room temperature sensor and humidity sensor. Depending on the current dew point, the supply temperature is increased.

Pump control

The cooling system can have one or two pumps. Twin pumps operate alternately to each other by automatically switching over once a week and starting the reserve pump automatically if the active pump fails. The pump can be configured to stop depending on the outside temperature.

Eco/comfort function

The eco function increases the supply setpoint. The increase can be adjusted. The controller has a time programme for the cooling circuit with two comfort periods per day.

Domestic hot water:

The function can be configured for one or two DHW systems. These have a constant supply-temperature control.

The controllers for the domestic hot water systems are PID controllers with appropriately adjustable control parameters.

Night reduction

The devices have individual time programmes for each DHW system with two normal temperature periods per day.

Pump control (only for DHW circuit 1)

A digital output signal is used to control the circulation pump.

Anti-Legionella function (only for DHW circuit 1)

The temperature setpoint can be raised to 62 °C once a day in order to prevent the growth of Legionella bacteria. The running time and the start time are adjustable.

Special controls:

Storage tank

A storage tank function can be activated. The charging pump starts and stops depending on the supply and return temperatures.

Pressure control

The flexotron800 controller can regulate a frequency-controlled pump using an analogue output signal in order to keep the pressure constant.

Differential temperature control

Using a differential thermostat function, a water tank, for example, can be heated using solar panels. A digital output starts the additional control loop pump.

Boiler control:

The device allows configuration of a boiler control loop (a control sensor) with between 1 and 4 boilers, each with one/two-speed or modulating burners.

Two control modes are available: PI control (modulating) or 2-point control (defined starting and stopping points for each boiler).

A fixed temperature, an outside temperature-based setpoint (curve), a demand-led setpoint (heating circuits, domestic hot water, storage tank) or an external setpoint for heat requirement can be configured as a setpoint.

The boiler control has an automatic release for malfunctions, and with multiple boilers the start sequence can be changed in order to balance the operating times.

Shared boiler pumps or individual pumps for each boiler with start/stop and adjustable automatic pump actuation can be configured.

The boiler return temperature can be limited to prevent the risk of condensation due to low temperatures. The limit affects a shared or individual return temperature sensor.

Consumption measurements:

Cold water consumption

The following values are calculated when monitoring cold water consumption:

- 24 hour consumption in litres, today (current day)
- 24 hour consumption in litres, yesterday (previous day)
- 24 hour consumption in litres, day before yesterday
- Lowest hourly consumption in litres, today
- Lowest hourly consumption in litres, yesterday
- Total consumption in m³. It is possible to reset the value.
- Water consumption (litres/min.)

Energy consumption

A digital pulse function can be configured for monitoring the heating energy consumption. The pulse constant can be adjusted.

The following consumption values are calculated:

- 24 hour consumption in kWh, today
- 24 hour consumption in kWh, yesterday
- 24 hour consumption in kWh, day before yesterday
- Total consumption in kWh/MWh; it is possible to reset the value.

Performance values

The heating performance is calculated by measuring the time between energy pulses. The following performance values are calculated:

- Instant value for a certain time or according to a certain number of pulses
- Average of the above instant value
- Max. value of the above instant value

Leakage monitoring

Once a week the regulating valves are closed and the energy consumption during a preset time is measured. If the energy loss is larger than the value set, an alert is issued.

Energy consumption values

Recording the heating energy consumption for monitoring. The total consumption is specified in MWh. This value can be reset.

Special functions (for ventilation and heating)

Devices without a display

The device models without an integrated display can be connected to an external RDB800F002 display via a 4P4C connector. The functions of this module are identical to those of the integrated display. Only one controller can be operated using an external display.

Disposal

When disposing of the product, observe the currently applicable local laws.

More information on materials can be found in the Declaration on materials and the environment for this product.

RDB800F002 accessory: External display for flexotron800 V2

Features

- Display: 4 lines of 20 characters each
- Illumination and character height 4.75 mm
- Clear operation using buttons
- Menus in 20 languages
- Functions identical to the integrated display/buttons of the flexotron800
- Electrical power supply internally via communication cable

Ambient conditions

Admissible ambient temperature	0...50 °C
Storage and transport temperature	-20...70 °C
Admissible ambient humidity	5...95% rh, no condensation

Construction

Dimensions W x H x D	115 × 95 × 25 mm
Power cable	3m long with permanently connected 4P4C connector to flexotron800
Fitting	Wall mounting on UP socket (hole spacing 60 mm) or on cabinet
Type of protection	IP 30

Dimension drawing for RDB800F002

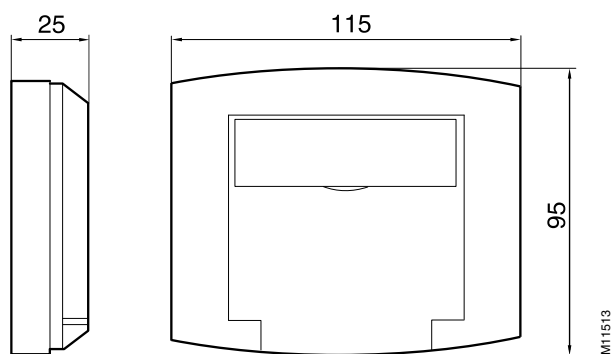

Note



Additional information

To connect the digital outputs with 24 V= power supply, see manuals

Connection diagrams with power supply 24 V~

RDT 808

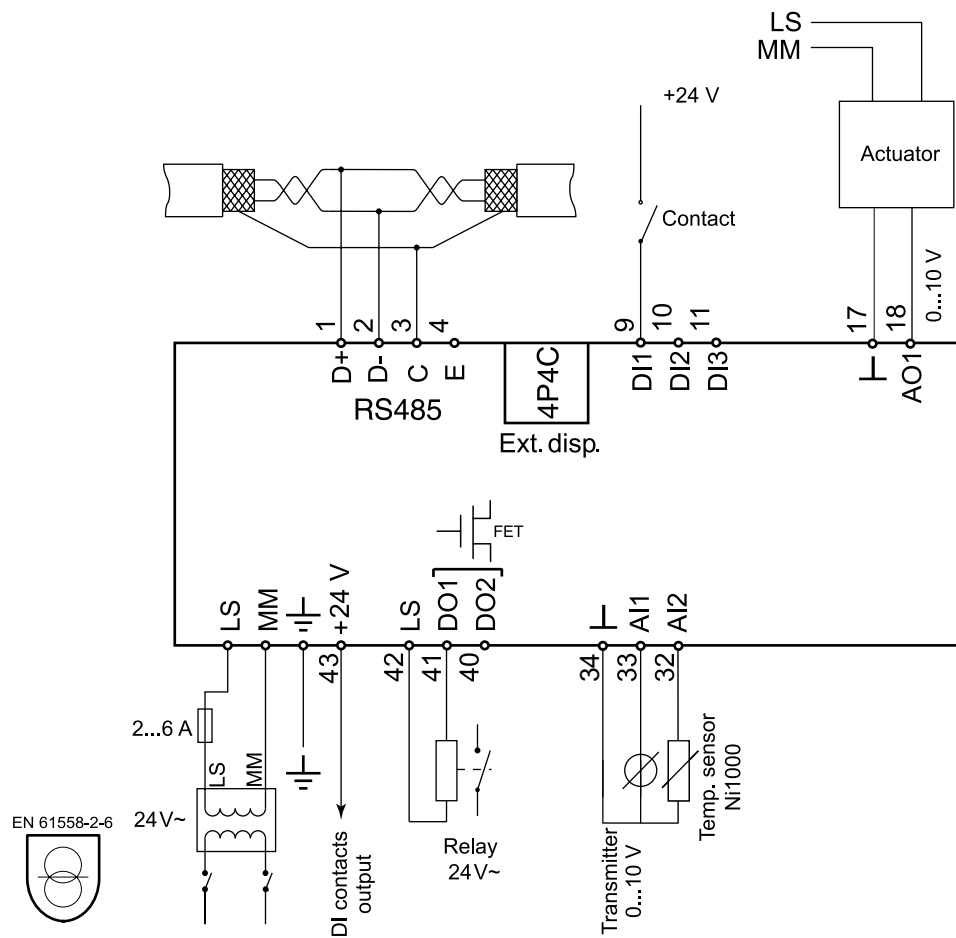

RDT 815

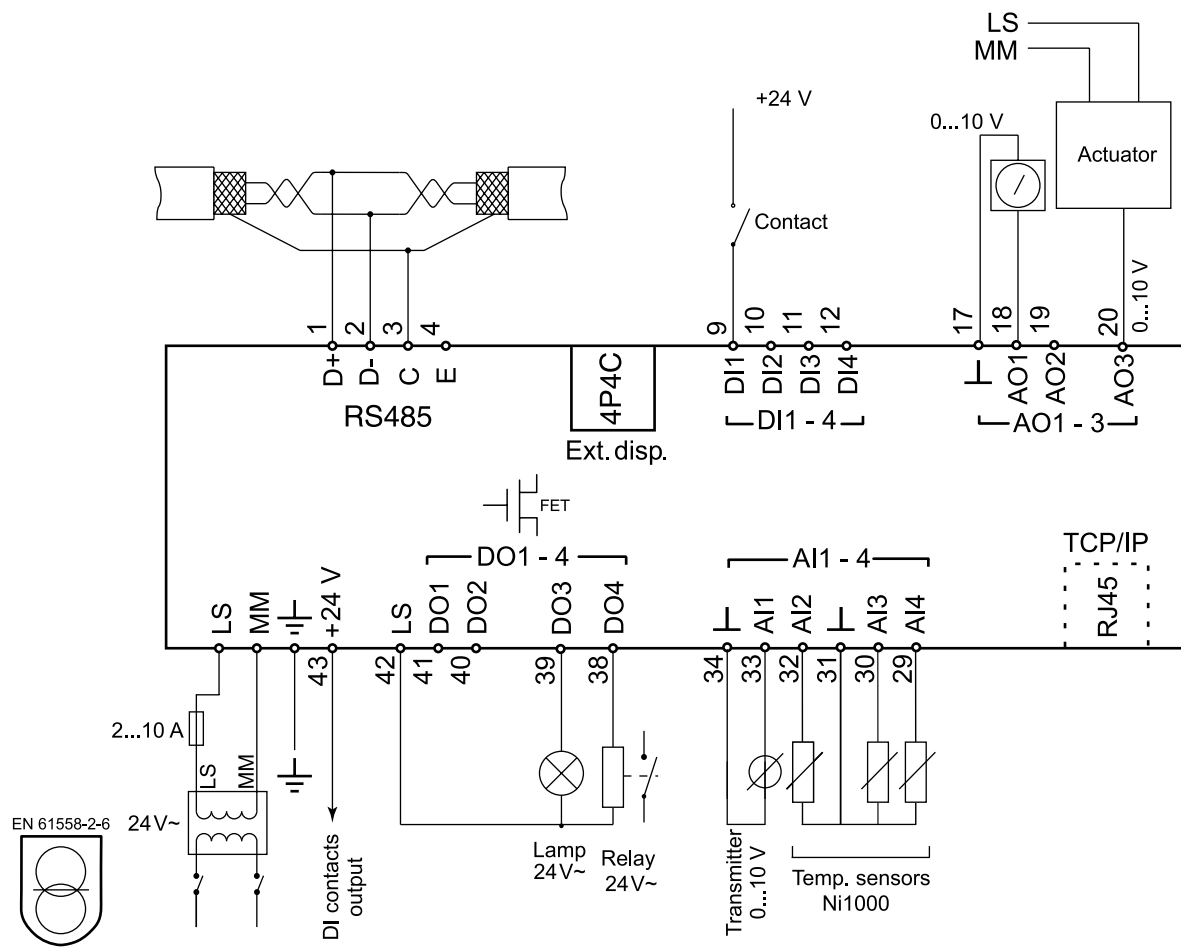

Options:

- RDT815F022
 - RDT815F032
 - RDT815F222
 - RDT815F232
- RJ45
TCP/IP

RDT 828

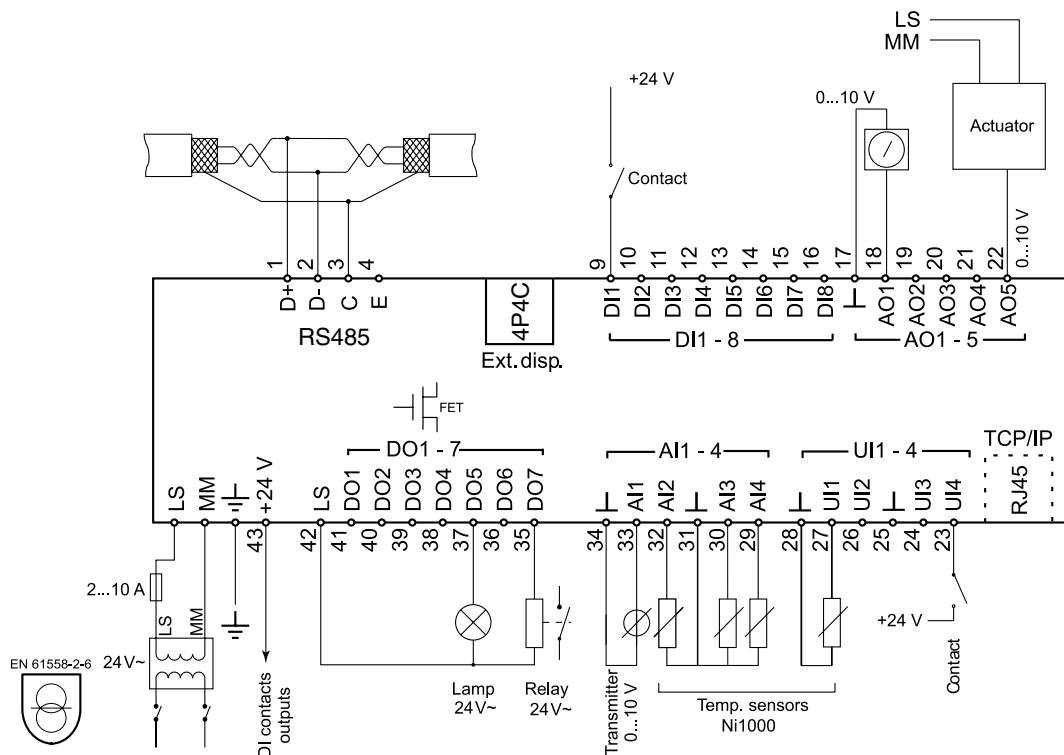

Options:

- RDT828F022
 - RDT828F032
 - RDT828F222
 - RDT828F232
- RJ45
TCP/IP

Dimension drawing

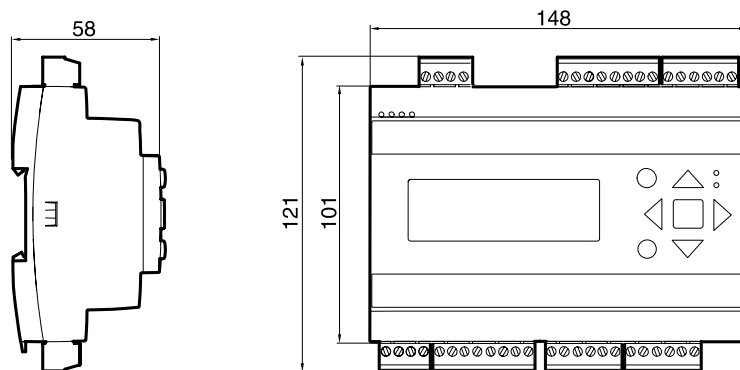

Application examples for ventilation

When the controllers are switched on for the first time, the basic function for ventilation or heating must be selected. Depending on the model, one or two basic configurations are prepared for the ventilation:

RDT 808: Fixed-value controller with heater

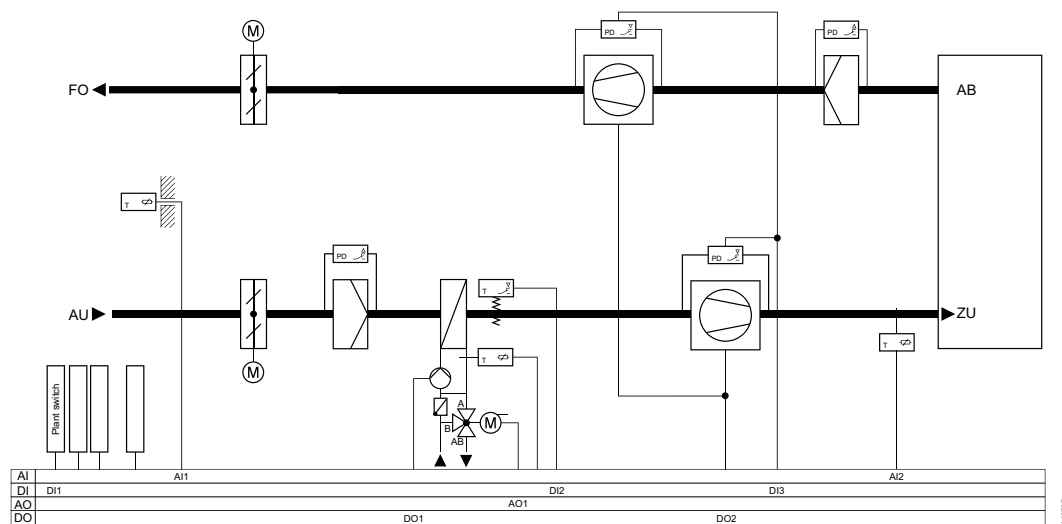

RDT 815: Fixed-value controller with heater, cooler and heat exchanger

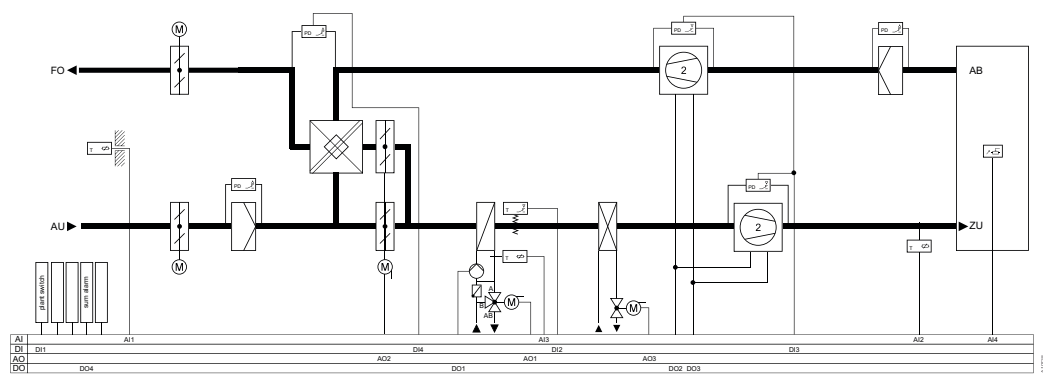

RDT 815: Cascade controller with heater, cooler and heat exchanger

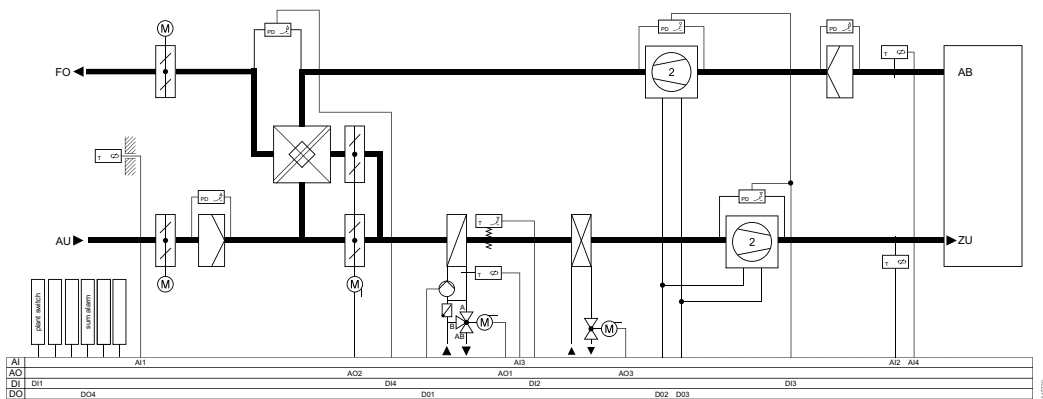

RDT 828: Cascade controller with heater, cooler and heat exchanger, and with CO₂ control

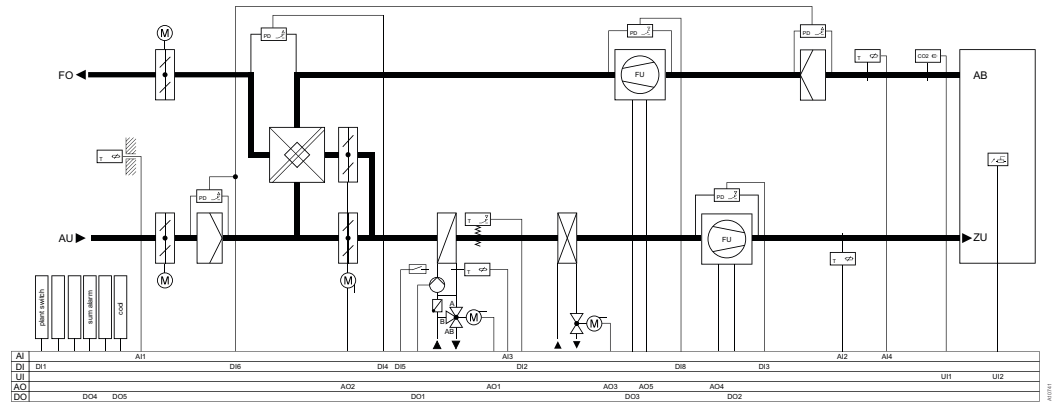

RDT 828: Cascade control with heater, cooler, recirculation air damper and humidity control

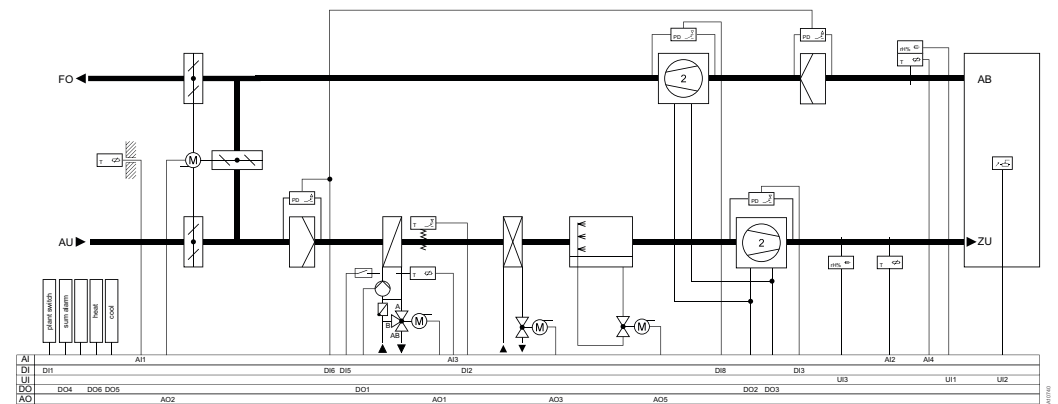

Application examples for heating

For the heating, the possible functions for heating circuit, cooling, domestic hot water and boiler are shown separately. The images contain the maximum possible elements supported by the software. However, the number of available I/O on the controller must be considered, as not all functions are possible at the same time.

Heating circuits:

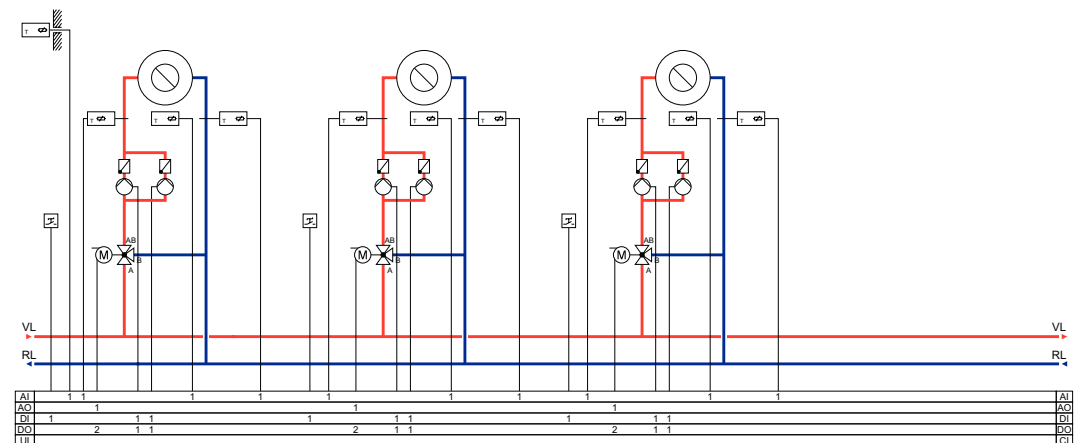

Cooling:

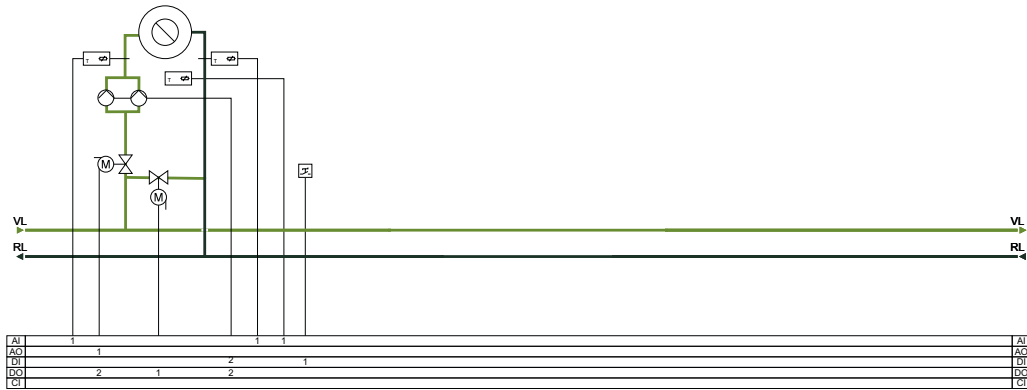

Domestic hot water:

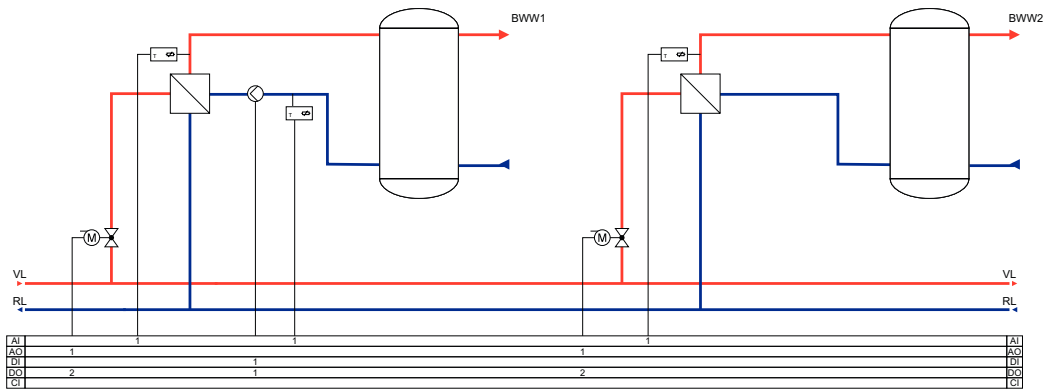

Boiler control:

