

DSB, DSF: Pressure monitors and pressure switches

How energy efficiency is improved

Control and monitoring according to needs and with no auxiliary energy

Features

- For regulating and monitoring pressure in liquids, gases and vapours
- Adjustable lower switching point
- Adjustable switching difference
- Sealable
- Pressure sensor made of brass for non-aggressive media (DSB)
- Pressure sensor made of stainless steel for aggressive media (DSF)
- SIL 2 certified as per EN 61508
- Approved for marine applications (GL and LR certified)

Technical data

Power supply		
	Maximum load with gold-plated contacts ¹⁾	400 mA, 24 V, 10 VA
	Minimum load with gold-plated contacts	4 mA, 5 V
	Maximum load with silver-plated contacts	10(4) A, 250 V~, 50 W, 250 V=
	Minimum load with silver-plated contacts	100 mA, 24 V
Parameters		
	Pressure connection	G½" male
Ambient conditions		
	Admissible ambient temperature	-20...70 °C
Construction		
	Housing	Transparent cover
	Housing material	Impact-proof thermoplastic
	Housing-mounted plug	Standard plug with female cable connector for cable Ø 6...10 mm
Standards and directives		
	Type of protection ²⁾	IP 65 (EN 60529)
	Protection class	I (IEC 60730)
	Test marks ³⁾	TÜV DWFS (SDBFS) ID: 0000006024
	PED	VdTÜV pressure information sheet 100 cat. IV (as SDBFS) EN 12952-11, EN 12963-9
	TRD	604, sheet 1 and sheet 2
	Ship approved	Germanischer Lloyd (GL) Lloyds Register
CE conformity as per		
	EMC directive 2004/108/EC	EN 61000-6-1, EN 61000-6-2, EN 61000-6-3, EN 61000-6-4
	Low-voltage directive 2006/95/EC	EN 60730-1, EN 60730-2-6
	Machine directive 2006/42/EC (according to appendix IIB)	EN ISO 12100
SIL conformity as per SIL 2		
	Standards	IEC 61508 parts 1-2 and 4-7 IEC 61511 parts 1-3

¹⁾ If the contacts are subjected to a load greater than specified, the gold plating will be destroyed. They are then classed merely as silver contacts and lose the properties of gold-plated contacts

²⁾ Depending on the fitting position, see the fitting instructions. The devices are not suitable for outdoor applications.

³⁾ DWFS (SDBFS): As a safety pressure limiter when an external electrical locking facility is fitted downstream in the circuit. Certificates can be downloaded from www.certipedia.com



DSB1**F001

DSF1**F001

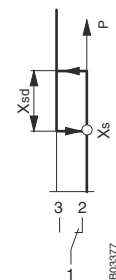
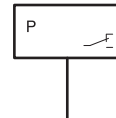

Overview of types

Type	Setting range	Switching difference	Maximum pressure	Max. sensor temp.	Admissible vacuum loading	Weight
DSB138F001	0...1.6 bar	0.25...0.65 bar	12 bar	70 °C	-0.7 bar	0.5 kg
DSB140F001	0...2.5 bar	0.25...0.75 bar	12 bar	70 °C	-0.7 bar	0.5 kg
DSB143F001	0...6 bar	0.3...1.6 bar	16 bar	70 °C	-0.7 bar	0.5 kg
DSB146F001	0...10 bar	0.8...3.7 bar	30 bar	70 °C	-1 bar	0.4 kg
DSB152F001	6...16 bar	1...4 bar	30 bar	70 °C	-1 bar	0.4 kg
DSB158F001	0...25 bar	1...7.5 bar	60 bar	70 °C	-1 bar	0.4 kg
DSB170F001	5...40 bar	1.4...7.5 bar	60 bar	70 °C	-1 bar	0.4 kg
DSF125F001	-1...1.5 bar	0.25...0.75 bar	12 bar	110 °C	-1 bar	0.5 kg
DSF127F001	-1...5 bar	0.3...1.5 bar	16 bar	110 °C	-1 bar	0.5 kg
DSF135F001	0...0.6 bar	0.12...0.60 bar	12 bar	110 °C	-1 bar	0.5 kg
DSF138F001	0...1.6 bar	0.25...0.7 bar	12 bar	110 °C	-1 bar	0.5 kg
DSF140F001	0...2.5 bar	0.25...0.75 bar	12 bar	110 °C	-1 bar	0.5 kg
DSF143F001	0...6 bar	0.3...1.5 bar	16 bar	110 °C	-1 bar	0.5 kg
DSF146F001	0...10 bar	0.8...3.0 bar	18 bar	110 °C	-1 bar	0.5 kg
DSF152F001	0...16 bar	1.2...3.8 bar	60 bar	110 °C	-1 bar	0.3 kg
DSF158F001	0...25 bar	1.5...8.0 bar	60 bar	110 °C	-1 bar	0.3 kg
DSF170F001	15...40 bar	1.7...8.2 bar	60 bar	110 °C	-1 bar	0.3 kg

⚡ DSB: Pressure sensor made of brass for non-aggressive media; X_S = lower switching point

⚡ DSF: Pressure sensor made of stainless steel for aggressive media; X_S = lower switching point

⚡ The switching difference must be within the setting range of the switching point. The minimum values of the switching difference are only possible in the lower setting range.

Accessories

Type	Description
0192222000	Cap nut with solder connector
0259239000	Reduction piece G $\frac{1}{2}$ " on 7/16" 20-UNF-2A for copper tubes of \varnothing 6 mm, brass
0292001000	Setpoint adjuster according to customer's wishes (setting accuracy: $\pm 3\%$ of the setting range, but a minimum of ± 0.2 bar)
0292002000	Switching difference according to customers' wishes (setting accuracy: $\pm 5\%$ of the setting range, but a minimum of ± 0.05 bar, with accessory 0292001 only)
0292004000	Setpoint adjuster sealed (with accessory 0292001 only)
0292150001	Fixing bracket for wall mounting
0296936000	Fixing brackets for rail: top-hat rail EN 60715, 35 \times 7.5 mm and 35 \times 15 mm
0311572000	Screw fitting for copper tubes of \varnothing 6 mm, brass
0381141001	Profile sealing ring, copper, for G $\frac{1}{2}$ "

⚡ 0296936000: with accessory 0292150001 only

Description of operation

For regulating and monitoring pressure in liquids, gases and vapours according to VdTÜV pressure information sheet 100. Especially suitable for applications in compact installations, for pipe mounting or wall mounting. When the pressure falls below the lower change-over point (adjustable setpoint X_S), the contacts switch from 1-3 to 1-2. When the pressure exceeds the lower change-over point by the amount of the switching difference X_{Sd} , the contacts switch from 1-2 to 1-3.

The switching difference can be set from outside using a grub screw: One revolution changes the switching difference by approx. 20% of the total switching difference range.

Intended use

This product is only suitable for the purpose intended by the manufacturer, as described in the "Description of operation" section.

All related product documents must also be adhered to. Changing or converting the product is not admissible.

Electrical serviceable life

- Mechanical serviceable life of the pressure pads according to pressure $100 > 2 \times 10^6$ switch strokes
- Typically

$\cos \varphi = 1$	$\cos \varphi = 0.6$	$\cos \varphi = 0.3^4)$
10 A, 250,000 switchings	3 A, 400,000 switchings	3 A, 250,000 switchings
5 A, 400,000 switchings		2 A, 400,000 switchings
2 A, approx. 10^6 switchings		1 A, 700,000 switchings



Note:

Using the device in SIL applications and as a safety device in machine construction changes its electrical serviceable life.

Typically to be considered:

10 A, 6,000 switchings

Technical appendix

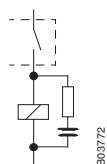

RC circuitry for inductive load

For the optimum RC circuitry, see the information from manufacturers of gates, relays, etc.

If this is not available, the inductive load can be reduced by applying the following rule of thumb:

- Capacity of the RC circuitry (μF) equal to or greater than the operating current (A)
- Resistance of the RC circuitry (Ω) approx. the same as the resistance of the coil (Ω)

Effect on switching difference

The switching difference depends slightly on the setpoint applied. The switching differences specified in the PDS sheet are typical values for the start of the range. The effect of the setpoint on the switching difference increases the switching difference by: $\Delta X_{sd} = (\text{setpoint } X_S - \text{start of the range}) \times 0.04$.

Materials

Materials that come into contact with the medium:

Pressure sensor made of brass (DSB): brass, stainless steel, nitrile rubber

Pressure sensor made of stainless steel (DSF): stainless steel, material no. 1.4104 and 1.4541

Engineering and fitting notes

The pressure limiters (SDBFS) conform to the European Directive on pressure equipment 97/23/EC and belong to device category IV as safety components. The devices also conform to Low-Voltage Directive 2006/95/EC and EMC Directive 2004/108/EC. The (SDBFS) devices are suitable for use in installations based on TRD 604, sheet 1 and sheet 2.

The devices can be used as safety pressure limiters (SDBFS) for falling or increasing pressure when an electrical interlock circuit is used (see application examples) and the requirements of DIN 57116 and VDE 0116 are fulfilled. The electrical plant devices must adhere to VDE 0660 or VDE 0435.

Use in safety applications

The devices fulfil the requirements of standard EN 61508 and can be used in safety applications up to SIL 2.

The information in the related operating instructions and in the safety manual must be considered.

The products are SIL2-compatible as per EN/IEC 61508 and EN/IEC 61511 and are therefore suitable for use in safety-oriented systems.

⁴⁾ $\cos \varphi < 0.3$: significant reduction in serviceable life. With RC circuitry, serviceable life as with $\cos \varphi > 0.3$ (also see technical appendix)

SIL compatibility figures

Type of sub-system		Type A
Operating mode		Low demand rate
Specific probability of failure on demand	PFDspec	3.12 E-05
Assumed demand rate	f_{np}	1/a
Test interval	T_i	1 a
Non-dangerous failure rate	SFF	>63.3%
Hardware error tolerance	HFT	0
Diagnostic degree	DC	0
Confidence level	1- α	95%
Diagnostic degree of cover for repeat check	PTC	>72.2%

Values for 1001 architecture at low demand rate

Assumed demand frequency	f_{np}	1 / a	1.14 E-04 /h
Total error rate	$\lambda_s + \lambda_D$	9.71 E-09 / h	10 FIT
Lambda dangerous detected	λ_{DD}	0.00 E+00 / h	0 FIT
Lambda dangerous undetected	λ_{DU}	3.56 E-09 / h	4 FIT
Lambda safe detected	λ_{SD}	0.00 E+00 / h	0 FIT
Lambda safe undetected	λ_{SU}	6.14 E-09 / h	6 FIT
Average time between two errors	MTTF	1.03 E+08 h	11,761 a
Average time between two dangerous errors	MTTF _D	2.81 E+08 h	32,046 a
Average probability of a failure when demand arises	PFD _{avg}	1.56 E-05	



When the minimum required hardware error tolerance of HFT=1 is considered, the pressure switches are compatible up to SIL 3 when operated redundantly.
 β factor: Proportion of failures that can have the same cause.

Architecture	β
1002	10%
1003	5%
1004	3%
2003	15%
2004	6%

Architectural and structural requirements must be tested by the end user.

Duration of use and repeat checks:

Approving a duration of use of over 5 years (+1.5 years in storage) is solely the responsibility of the operator when considering the specific usage conditions and the prescribed test cycles.

The operating mode as per IEC/EN 61508-4, article 3.5.12, has been defined as "operating mode with low demand rate".

To check that the pressure switches are functioning correctly, repeat checks must be performed in the installations. These checks should be performed a maximum of 10 times per year. But at least once a year.

Applications as a safety device in machine construction

Based on standard ISO 13849-1 and for use in systems with a high demand rate, the following parameters were determined.

- Maximum admissible demand rate: 50 per year
- $B10_d = 6000$
- PFH = 9.51 E-08

A single pressure monitor or limiter can be used within the operating range of standards EN ISO 13849-1 to PL c. To safeguard against higher risks (PL d, PL e), they must be used redundantly, and in the downstream safety module, the plausibility of the switching states must be monitored continuously. Architectural and structural requirements must be tested by the end user.

Disposal

When disposing of the product, observe the currently applicable local laws.
 More information on materials can be found in the Declaration on materials and the environment for this product.

Additional information

Technical information	
Fitting instructions	
DSB1..., DSF1..., DSH1..., DSL1..	P100014216
Declaration on materials and the environment	MD 23.760
Safety manual	D100237466

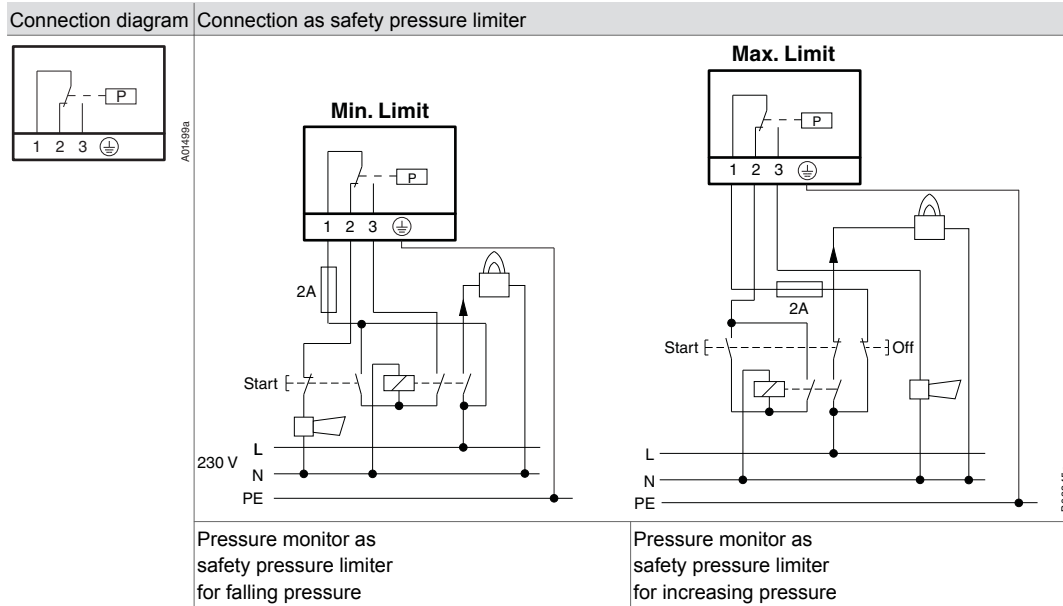

Dimension drawing

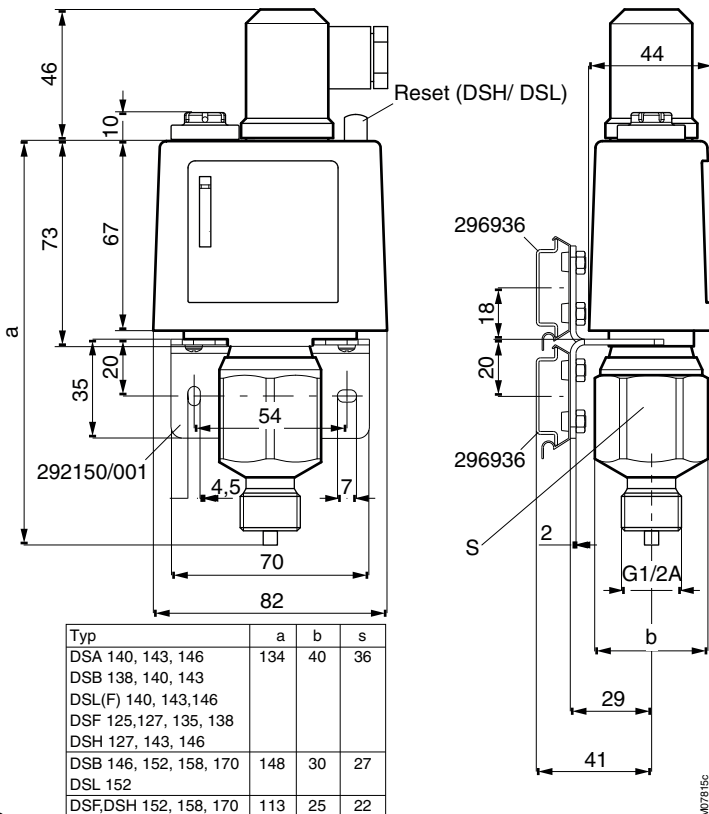

M07815c

M07815c

