

EY-IO 572: I/O module, analogue outputs, universal and digital inputs, modu572

How energy efficiency is improved

SAUTER EY-modulo 5 technology: modular, fast and universal

Features

- Part of the SAUTER EY-modulo 5 system family
- 15 inputs and outputs
- Plug-in element for extending the modu525 automation station (AS)
- Power supply from modu525 AS
- Modular design (baseplate/electronics)
- Direct labelling on the front
- Can be equipped with a local operating and indicating unit



EY-IO572F001

Technical data

Power supply

Power supply	From modu525 AS via I/O bus
Power consumption ¹⁾	≤ 1.8 VA/0.8 W
Power loss	≤ 0.8 W
Current consumption ²⁾	≤ 110 mA

Ambient conditions

Operating temperature	0...45 °C
Storage and transport temperature	-25...70 °C
Admissible ambient humidity	10...85% rh, no condensation

Inputs/Outputs

Analogue outputs	4 × 0...10 V/0...20 mA (source)
Load	≤ 20 mA
Universal inputs	8
Analogue	Ni1000/Pt1000, U/I/R, pot
Digital	DI (≤ 3 Hz)
Digital inputs	3 fixed allocation
Pulse counter	≤ 10 Hz

Interfaces and communication

Connection for modu6 (LOI)	6-pin, integrated
Connection, I/O bus	12-pin, integrated
Connection terminals	24 (0.5...2.5 mm ²)

Construction

Fitting	On top-hat rail
Dimensions W x H x D	42 × 170 × 115 mm
Weight	0.29 kg

Standards and directives

Type of protection	IP 30 (EN 60529)
Protection class	I (EN 60730-1)
Environment class	3K3 (IEC 60721)

CE conformity as per	EMC directive 2004/108/EC	EN 61000-6-1, EN 61000-6-2, EN 61000-6-3, EN 61000-6-4
----------------------	---------------------------	---

Overview of types

Type	Properties
EY-IO572F001	I/O module, analogue outputs, universal and digital inputs, modu572

¹⁾ On the primary side of modu525 base station (230 V~)

²⁾ Supply via modu525 base station



Accessories**Local operating and indicating units (LOI)**

Type	Description
EY-LO630F001	16-LED indication, bi-colour
EY-LO670F001	4 setpoint transmitters (A-0...100%), 8 LEDs for operation/indication

Components

Type	Description
0920360003	24 V I/O module baseplate (pack of 3)
0929360572	Electronics module, modu572, 8 UI, 4 AO 24 V, 3 DI

Description of operation

The modu572 I/O module is used for actuation with a standard signal (0...10 V), recording digital (alarm/status) and analogue inputs (Ni/Pt1000, U/I/Pot) in operational systems, e.g. in HVAC engineering.

The I/O module has a total of 4 analogue outputs and 8 universal inputs.

Intended use

This product is only suitable for the purpose intended by the manufacturer, as described in the "Description of operation" section.

All related product documents must also be adhered to. Changing or converting the product is not admissible.

Engineering notes

The modu572 I/O module is generally comprised of two components. The baseplate in which the I/O bus system and the connection terminals are integrated and the actual I/O module electronics.

Fitting/assembly

The baseplate of the I/O module is mounted in a cabinet using a top-hat rail (EN 60715) and connected on the side directly to the I/O bus of the modu525 AS or modules. This work must only be carried out in the de-energised state.

The baseplate contains the "bus module", which is responsible for power supply and continuous communication. This ensures that faults due to a failure or partial defect in the electronic component do not affect the function of other downstream modules.

Removing/inserting the I/O module electronics from/to the baseplate is possible while the AS is in operation.

To ensure plant safety and to avoid any faults at inputs or outputs, the I/O module electronics should only be removed or inserted while the base station is switched off.

Labelling concept

The I/O module can be labelled with a paper insert in the frontal transparent cap. The labelling is usually carried out using texts generated from CASE Suite, and the labels are printed on normal A4 paper using a commercial printer.

Assigning modules to AS

The I/O module electronics are encoded on the hardware side using pin inserts so that only the appropriate baseplate can be used. The modu525 AS detects whether a module baseplate is plugged into the I/O bus. Baseplate number and assignment of module types for the I/O modules on the AS are defined with CASE Suite. This information is permanently stored in the AS.

LED indicator/function

The I/O module is equipped with a system LED that indicates the operating modes as follows:

System LED

LED I/O bus	Status	Indicator sequence	Description
No designation	Continuous green	—————	Module in operation
	Pulsating green	o o o o o o	Module not assigned with the base station
	Rapid pulsating red	oooooooooooo	AS in configuration, update or download
	Flashing red	o o o o o o o	Module incorrectly assigned or internal error
	Alternating green – red – OFF	oo oo oo oo oo	Lamp test active (indicator type priority)
	No indicator		No power supply

Output/inputs

The I/O module has a total of 4 analogue outputs, 8 universal inputs and 3 digital inputs.

Outputs

Number of outputs	4
Type of outputs	Analogue outputs 0(2)...10 V= or 0...20 mA ≥ to 20 mA (source) per output Return line grounded
Update	100 ms
Resolution	13 bits

The output voltage is taken from between an output terminal (a0...a3) and a ground terminal. The outputs are designed as sources only and can be loaded with up to 20 mA. The changeover to a current signal is performed automatically depending on the load.

The outputs are protected against static discharges, not against AC or DC that is present.

Universal inputs

Number of inputs	8 (UI)
Type of inputs (software coding)	Ni1000 (DIN 43760) Pt1000 (IEC 751) Voltage measurement (U) Current measurement (I) channel u8, u9 only! Potentiometer input (Pot) Resistance (R)
<i>Protection against external voltage</i>	
Ni/Pt/U/R/Pot/DI	±30 V/24 V~ (without destruction)
I (channel u8, u9)	+12 V/-0.3 V (without destruction)
Reference	U _{ref} 1.23 V (terminal no. 22)
Scan rate 100 ms	Channels u8, u12
Scan rate 500 ms	Channels u9, u10, u11, u13, u14, u15
Resolution	14 bits
<i>Measuring ranges</i>	
Voltage (U)	0 (2)...10 V, 0 (0.2)...1 V
Current (I)	0 (4)...20 mA
Potentiometer (Pot.)	0...1 (100%) with 3-wire connection (1...2.5 kΩ)
Reference	U _{ref} 1,23 V (terminal no. 22) > 1 kΩ, load max. 10 mA
Resistance (R)	200...2500 Ω
<i>Temperature</i>	
Ni1000	-50...+150 °C
Pt1000	-50...+150 °C
Digital input	Potential-free contacts with ground connection opto-coupler, transistor (open collector) approx. I _{out} = 1.2 mA
Pulse counter	Max. 3 Hz (100 ms update interval) Max. 0.5 Hz (500 ms update interval)

Temperature measurement (Ni/Pt)

The Ni/Pt1000 sensors are connected using two wires between one of the input terminals for universal inputs (channel u8...u15) and a ground terminal. The inputs require no calibration and can be used directly. Line resistance of 2 Ω is pre-compensated as standard. With the correct line resistance of 2 Ω, (cable cross-section 1.5 mm²), the power cable (wire) may be no more than 85 m. Larger line resistances can be compensated by the software. The measurement current is pulsed to ensure that the sensor is not heated (I_{meas} approx. 0.3 mA).

Voltage measurement (U)

The voltage to be measured is connected between an input terminal for universal inputs (channel u8...u15) and a ground terminal. The signal must be potential-free. The measuring ranges with or without offset 0 (0.2)...1 V or 0 (2)...10 V are selected through the software. The internal resistance R_i of the input (load) is 9 MΩ.

Current measurement (I)

The current can only be measured at two inputs. The current to be measured is connected at one of the two input terminals for universal inputs (channel u8, u9) and a ground terminal. The current signal must be potential-free. The measuring ranges with or without offset 0 (4)...20 mA are selected via the software. The internal resistance R_i of the maximum input current must be limited to 50 mA. The internal resistance R_i is $< 50 \Omega$.

Potentiometer measurement (Pot.)

The potentiometer is connected between an input terminal for universal inputs (channel u8...u15), a ground terminal and the terminal U_{ref} (reference voltage). To avoid overloading the reference output, the lowest potentiometer value should not drop below 1 k Ω . The reference output is not short circuit-proof. The upper value of 2.5 k Ω is prescribed to guarantee a stable, fault-independent measurement.



Note

To maintain measuring accuracy, ground connections should always be connected to the same type of input.

For an optimum connection, we recommend connecting one ground terminal of the I/O module directly with the AS or each appropriate cabinet terminal.

Digital inputs (DI with UI)

The AS also records binary information with the universal inputs. The information (alarm/status) is connected between an input terminal (u8...u15) and a ground terminal. The station applies a voltage of approximately 13 V to the terminal. If a contact is open, this usually corresponds to an INACTIVE state (bit = 0). If a contact is closed, there is an ACTIVE state (bit = 1) and 0 V is applied, giving a current of approximately 1 mA. Short-term changes (default 33 ms) between the station queries are saved briefly and processed at the next cycle.

Every input can be defined individually as an alarm or a status through software parameter setting. With a local indicating unit (e.g. modu630 accessory) the digital inputs can be displayed.

Digital inputs (DI fixed)

Number of inputs	3
Type of inputs	Potential-free contacts with ground connection Opto-coupler Transistor (open collector)
Pulse counter	≥ 10 Hz (100 ms scan rate)
Pulse length	> 4 ms
Protection against external voltage	± 30 V/24 V~ (without destruction)
Max. output current	1.2 mA to ground
Scan rate	100 ms

The binary information is connected between one of the input terminals (d5...d7) and the ground. The module applies a voltage of approximately 13 V to the terminal. If a contact is open, this corresponds to an INACTIVE state (bit = 0). If a contact is closed, there is an ACTIVE state (bit = 1) and 0 V is applied, giving a current of approximately 1 mA. Short-term changes (default 33 ms) between the station queries are saved briefly and processed at the next cycle. Every input can be defined individually as an alarm or a status through software parameter setting.

With a local indicating unit (e.g. modu630 accessory) the digital inputs can be displayed.

Pulse counters (CI with DI)

At the digital inputs, counter inputs of potential-free contacts, opto-couplers or transistors with an open collector can be connected. The maximum pulse frequency may be up to 50 Hz. To ensure that switching contacts are recorded correctly, a de-bounce time of 5 ms is used. Pulses may be captured on falling, rising or both edges; the minimum pulse duration should be four times the debounce time.

Technical specifications of the inputs and outputs

Universal input	Measuring range	Resolution	Accuracy of the measuring span plus measured value	
Ni/Pt1000	-50...+150 °C	< 0.05 K	$\pm 0.5\%$	0.5%
U (0/0.2...1 V)	0.02...1.1 V	< 0.1 mV	$\pm 0.5\%$	0.5%
U (0/2...10 V)	0.15...10.2 V	< 1 mV	$\pm 0.5\%$	0.5%
I (0/4...20 mA)	0.02...22 mA	< 0.02 mA	$\pm 1\%$	2%
R	200...2500 Ω	< 0.1 Ω	$\pm 0.2\%$	1%
Pot (≥ 1 k Ω)	1...100%	$< 0.5\%$	$\pm 1\%$	1%
Analogue output	Range of adjustment		Pitch error	

Universal input	Measuring range	Resolution	Accuracy of the measuring span plus measured value	
AO (0/2...10 V / 0...20 mA)	0.01...10.2 V	< 2 mV	1%	1%
Binary input (0-I)	Universal input (UI)	Digital input (DI)		
Switching threshold active	> 3 V	> 4 V		
Switching threshold inactive	< 1.5 V	< 2.5 V		
Switching hysteresis	> 0.4 V	> 0.4 V		

Channel and terminal assignment

Description modu572	Channel	Schematic	Terminals	
			Signal	GND
Analogue output (0...10V)	0	a0	2	1
	1	a1	4	3
	2	a2	6	5
	3	a3	8	7
Digital input (Pulse counter CI)	5	d5	10	9
	6	d6	11	
	7	d7	12	
Universal input (Ni/Pt1000/U/R/Pot) Current measurement only on channels 8, 9 or terminals 13, 14	8	u8	13	
	9	u9	14	
	10	u10	15	16
	11	u11	17	18
	12	u12	19	20
	13	u13	21	
	14	u14	23	
	15	u15	24	
Reference voltage 1.23 V		Ref	22	

Connection of local operating unit

The I/O module can be complemented with local operating and indicating units (LOI). A unit can be installed and removed during operation (hot-pluggable) without affecting functions of the AS or I/O module.

For modu572, the following operating and indicating units can be used:

- EY-LO630F001: 16 LED indicators
- EY-LO670F001: 4 slide switches (automatic mode "A", 0...100%) with LED indicators

The function corresponds to the standard EN ISO 16484-2:2004 for local override and indicating units.

Detailed information about the actuation function and LED indicator can be found in the PDS 92.081 for EY-LO 6**.

If an incompatible operating unit is connected, this status is indicated by the flashing of all LEDs (red and yellow); there is no risk of the I/O module being destroyed.



Note

Before insertion, all controller positions (AUTO) must be checked to ensure that no undesired signal values are issued. When the unit is removed, all outputs are operated with the automatic values of the AS or I/O module.



In accordance with the standard, the local override and indication devices allow restricted operation of plant components without the involvement of the AS intended for the application. Outputs of the AS or the I/O modules in manual position may change the value briefly when the user program is downloading. The local operating unit can be used to actuate the analogue outputs in the AS directly even without a user application (CASE Engine).

Disposal

When disposing of the product, observe the currently applicable local laws.

More information on materials can be found in the Declaration on materials and the environment for this product.

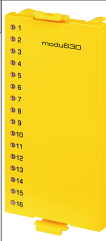
Accessories

EY-LO630F001	Single unit used for indication of the data points of the modu572 I/O or modu525 AS	
	16 LEDs	
EY-LO670F001	Single unit used for indication of the data points of the modu572 I/O or modu525 AS	
	8 LEDs	
	4 slide switches with LED indicator	Setpoint transmitter 0...100%, manual position indication yellow LED indication red (freely configurable for Event/Alarm)

Connection diagram

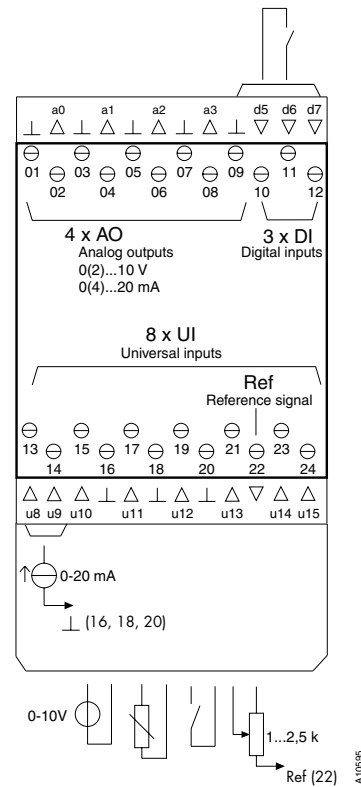

Dimension drawing

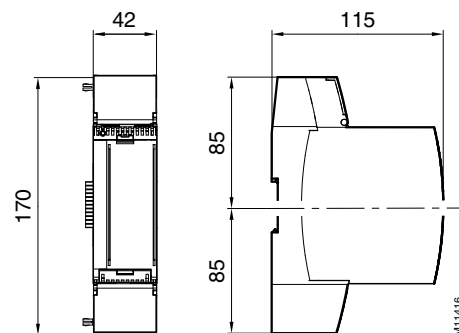

Fr. Sauter AG
 Im Surinam 55
 CH-4016 Basel
 Tel. +41 61 - 695 55 55
 www.sauter-controls.com