

## BQD: 3-way flanged valve, PN 6

### How energy efficiency is improved

Efficient use in continuous control systems

### Features

- Continuous control of cold and hot water in closed circuits
- Water quality as per VDI 2035
- In combination with valve actuators AVM 322(S), AVM 234S and AVF 234S as control unit
- Not suitable for drinking water or potentially explosive atmospheres
- Valve with flange connection as per EN 1092-2, seal form B
- Regulating valve, free of silicone grease, painted black
- Equal-percentage control passage characteristic, can be set with SUT (SAUTER Universal Technology) valve actuators to linear or quadratic
- Mixing passage, linear characteristic
- The control passage is closed when the spindle is moved out
- Used as control valve or as distribution valve
- Valve body with seat made of grey cast iron
- Stainless-steel spindle
- Plugs made of stainless steel with metal-to-metal seal
- Stuffing box made of stainless steel with wiper ring and double O-ring seal made of EPDM



**BQD**

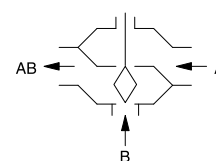

**Control valve**

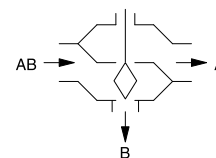

**Distribution valve**

### Technical data

#### Parameters

Nominal pressure	PN 6
Connection	Flange as per EN 1092-2, form B
Valve characteristic, control passage	Equal-percentage
Valve characteristic, mixing passage	Linear
Control ratio of valve	> 30:1
Stuffing box	2 EPDM O-rings
Leakage rate	Class III as per DIN EN 60534-4 (0.001 x $k_{VS}$ )
Valve stroke	20 mm (DN 65...80) 40 mm (DN 100)

#### Ambient conditions<sup>1)</sup>

Operating temperature <sup>2)</sup>	-10...150 °C
Operating pressure	Up to 120 °C 6 bar At 150 °C 5.4 bar Between 120 °C and 150 °C, a linear interpolation can be performed

#### Standards and directives

Pressure and temperature data	EN 764, EN 1333
Flow parameters	EN 60534, (page 3)
Pressure Equipment Directive	97/23/EC (fluid group II) No CE label, article 3.3

#### Overview of types

Type	Nominal diameter	$k_{VS}$ value	Weight
BQD065F300	DN 65	63 m <sup>3</sup> /h	14.8 kg
BQD080F300	DN 80	100 m <sup>3</sup> /h	21 kg
BQD100F300	DN 100	160 m <sup>3</sup> /h	31 kg

#### Accessories

Type	Description
0372336180	Adaptor (required when temperature of the medium is 130...150 °C) from DN 65
0378284100	Stuffing box heater 230V~, 15 W for medium below 0 °C

<sup>1)</sup> Air humidity must not exceed 75%

<sup>2)</sup> At temperatures below 0 °C, use a stuffing box heater



Type	Description
0378284102	Stuffing box heater 24V~, 15 W for medium below 0 °C
0378369101	Complete replacement stuffing box from DN 65

### Combination of BQD with electric actuators

**i** *Warranty: The technical data and pressure differences indicated here are applicable only in combination with SAUTER valve actuators. The warranty does not apply if used with valve actuators from other manufacturers.*

**i** **Definition of  $\Delta p_s$ :** *Maximum admissible pressure drop in the event of a malfunction (pipe break after the valve) at which the actuator reliably closes the valve by means of a return spring.*

**i** **Definition of  $\Delta p_{max}$ :** *Maximum admissible pressure drop in control mode at which the actuator reliably opens and closes the valve.*

### Combination of BQD with electric actuator, actuating power 1000 N

Actuator	AVM322F120 AVM322F122	AVM322SF132
Actuating power	1000 N	1000 N
Control signal	2-/3-point	2-/3-pt., 0...10 V, 4...20 mA
Running time	120/240 s	120/80 s

#### $\Delta p$ [bar]

As control valve	$\Delta p_{max}$	$\Delta p_{max}$
BQD065F300	2.5	2.5
BQD080F300	1.5	1.5

As distribution valve		
BQD065F300	2.5	2.5
BQD080F300	1.5	1.5

 *Maximum media temperature: 100 °C*

### Combination of BQD with electric actuator, actuating power 2500 N, 2000 N

Actuator	AVM234SF132	AVF234SF132 AVF234SF232
Actuating power	2500 N	2000 N
Control signal	2-/3-pt., 0...10 V, 4...20 mA	2-/3-pt., 0...10 V, 4...20 mA
Running time DN 65, DN 80	40/80/120 s	40/80/120 s
Running time DN 100	80/160/240 s	80/160/240 s

#### $\Delta p$ [bar]

As control valve	$\Delta p_{max}$	$\Delta p_{max}$	$\Delta p_s$
BQD065F300	3.0	3.0	5.1
BQD080F300	3.0	3.0	3.4
BQD100F300	2.0	2.0	2.2

As distribution valve			
BQD065F300	1.0	1.0	6.0
BQD080F300	0.75	0.75	6.0
BQD100F300	0.5	0.5	6.0

 *At temperatures above 130 °C, accessories are required*

### Description of operation

The valve can be moved to any intermediate position with an electric actuator. When the spindle is moved out, the control passage of the valve is closed. These valves may be used as control valves or distribution valves. The flow direction marked on the valve must be observed. The flow parameters correspond to EN 60534.



## Note

These valves are intended for HVAC control functions. Do not use them as shut-off units.

## Used as a control valve

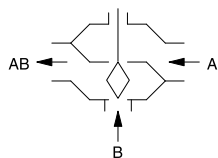

## Used as a distribution valve

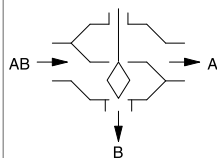

These control valves are characterised by their reliability and precision and make an important contribution towards environmentally friendly regulation. They meet difficult challenges such as the quick-closing function, overcoming differential pressures and controlling medium temperatures, all with a low noise level.

The valve spindle is automatically and firmly connected to the actuator spindle. The stainless steel plug controls the equal-percentage flow rate in the control passage. To compensate for the complementary characteristic of the consumer and ensure a constant quantity of medium regardless of the valve position, the mixing passage acts with a linear characteristic. The tightness of the valve is ensured by the seat incorporated in the body.

The stuffing box is maintenance-free. This consists of a stainless steel body, two O-rings, a wiper ring and a grease reserve. This is free of silicone grease, and silicone oil may not be used for the spindle.

### Intended use

This product is only suitable for the purpose intended by the manufacturer, as described in the "Description of operation" section.

All related product documents must also be adhered to. Changing or converting the product is not admissible.

### Engineering and fitting notes

The valves are combined with the valve actuators without a spring return or with valve actuators with a spring return. The actuator is mounted directly on the valve and fastened with screws. The actuator is connected with the valve spindle automatically. During the commissioning of the system, the actuator moves out. The connector automatically closes when it reaches the lower valve seat. The stroke of the valve is also detected by the actuator. No other adjustments are required. Therefore the force on the seat is always the same and the smallest amount of leakage is ensured. With the SUT actuators, the characteristic can be set to linear or quadratic as required.

### Additional technical data

Technical information	
SAUTER slide rule for valve sizing	P100013496
Technical manual on control units	7 000477 001
Parameters, fitting notes, control, general information	Applicable EN, DIN, AD, TRD and UVV regulations
Fitting instructions	P100013463
AVM 234S assembly	MV 505919
AVF 234S assembly	MV 505920
AVM 322(S) assembly	P100011900
Declaration on materials and the environment	MD 56.113

### Fitting position

The control unit can be fitted in any position, but the hanging position is not recommended. Condensate, drops of water, etc. must be prevented from entering the actuator. When installed horizontally, and with regard to the valve spindle, the admissible actuator or support weight, without structural support, is max. 25 kg.

When the actuator is mounted on the valve, make sure the plug is not twisted on the seat (this can damage the sealing surface). When insulating the valve, it may only be insulated up to the connecting clip of the actuator.

### Using with water

So that impurities are retained in the water (welding beads, rust particles, etc.) and the spindle seal is not damaged, we recommend installing collecting filters, for example one for each floor or pipe run.

Water requirements according to VDI 2035. When using an additive in the water, the compatibility of the materials must be checked with the manufacturer of the medium. The materials table shown below may be used. When glycol is used, we recommend using a concentration of between 20% and 55%.

#### Other information regarding hydraulics and noise in systems

The valves can be used in a low-noise environment. To prevent noise, the pressure differences  $\Delta p_{\max}$  listed below should not be exceeded. These values are listed as recommended values in the table of pressure losses. The pressure difference  $\Delta p_v$  is the maximum pressure that may act on the valve regardless of the stroke position, in order that the risk of cavitation and erosion is limited. These values are irrespective of the actuator force. Cavitation accelerates wear and causes noises. To prevent cavitation, the pressure differential on the valve should not exceed the value  $\Delta p_{\text{krit}}$ :

- $\Delta p_{\text{krit}} = (p_1 - p_v) \times 0.5$
- $p_1$  = upstream pressure before the valve (bar)
- $p_v$  = steam pressure at operating temperature (bar)

The calculation works with absolute pressure.

For the spring return, the stated  $\Delta p_s$  values are also the permissible differential pressure up to which the actuator can guarantee that the valve is closed in the event of an incident. Because this is a quick-closing function with a "fast" stroke movement (using a spring), this value can exceed  $\Delta p_{\max}$ .

Flow-rate chart

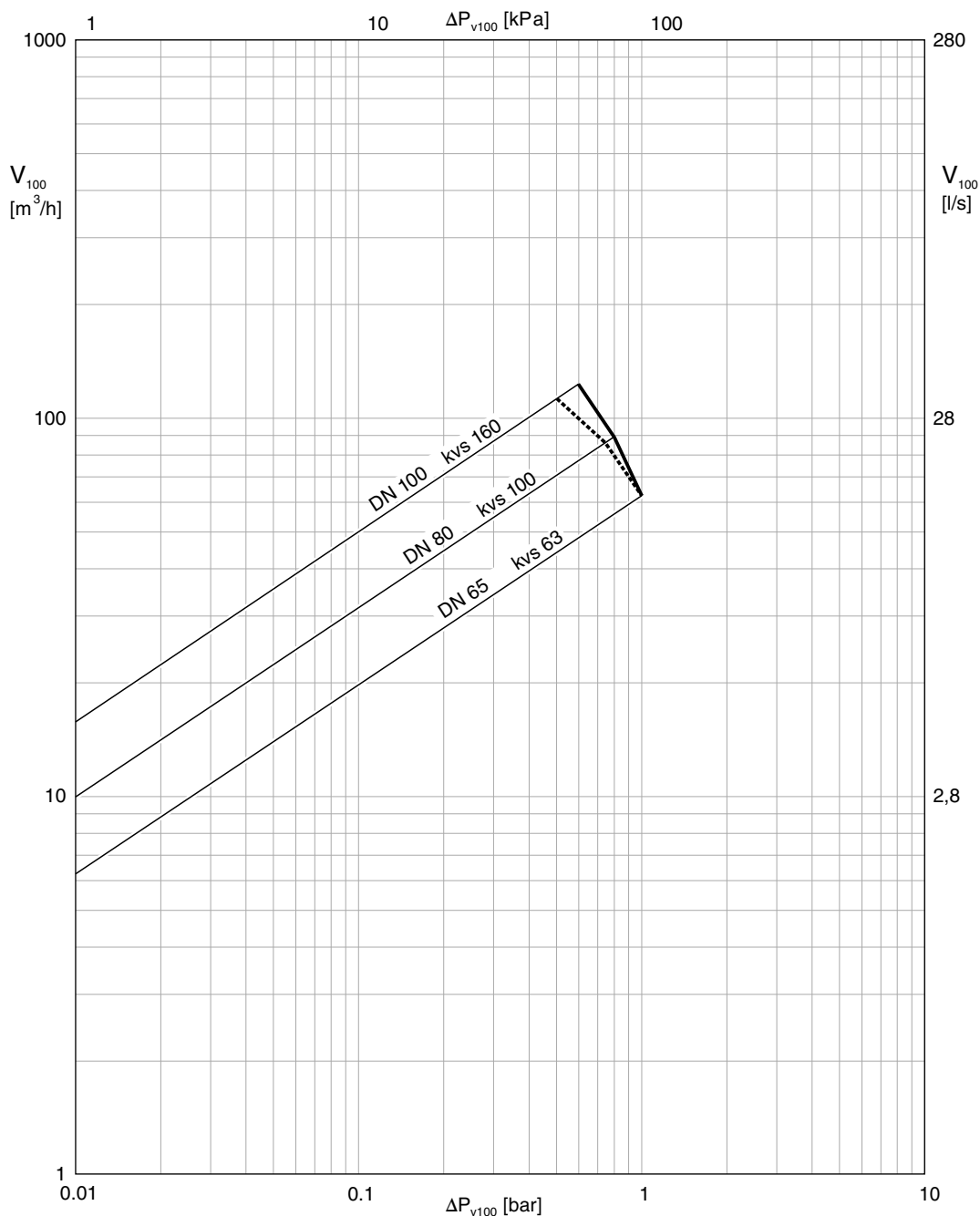

-----	$\Delta p_v$ when used as a control valve
-----	$\Delta p_v$ when used as a distribution valve

Type	$\Delta p_v$	
	Used as a control valve	Used as a distribution valve
BQD065F300	1.0	1.0
BQD080F300	0.8	0.75
BQD100F300	0.6	0.5

Additional version information

Valve body made of grey cast iron as per EN 1561, code EN-GJL-250, material number EN-JL 1040 with smooth drilled flanges as per EN 1092-2, seal form B.  
 Valve body protected by matt paint RAL 9005 jet black.  
 Fitted in the piping with welding flange as per EN 1092-1.

Valve fitting length as per EN 558-1, basic series 1.  
Flat seal on valve body made of asbestos-free material.

#### Material numbers as per DIN

DIN designation	DIN materials	DIN designation
Valve body	EN-JL 1040	EN-GJL-250 (GG25)
Valve seat, control passage	EN-JL 1040	EN-GJL-250
Valve seat, mixing passage	1.4021	X20Cr13
Spindle	1.4021	X20Cr13
Plug	1.4021	X20Cr13
Stuffing box	1.4104	X12CrMoS-17

#### Additional details on the definitions of pressure difference

##### $\Delta p_v$ :

Maximum admissible pressure difference over the valve at every stroke position, limited by noise level and erosion.

With this parameter, the valve is characterised as a flow element with specific hydraulic behaviour. Monitoring the cavitation and erosion along with the associated noise increases the service life and the operational capacity.

##### $\Delta p_{max}$ :

Maximum admissible pressure difference over the valve at which the actuator can reliably open and close the valve.

Static pressure and flow effects are considered. This value ensures trouble-free stroke movement and tightness. The value  $\Delta p_v$  of the valve is never exceeded.

##### $\Delta p_s$ :

Maximum admissible pressure difference over the valve in the event of a malfunction (e.g. power failure, excessive temperature or pressure, pipe break) at which the actuator can close the valve tightly and, if necessary, maintain the entire operating pressure against atmospheric pressure. Because this is a quick-closing function with a rapid stroke movement,  $\Delta p_s$  can be greater than  $\Delta p_{max}$  or  $\Delta p_v$ . The disruptive flow effects that arise here are quickly passed through and are of minor importance in this mode of operation.

For 3-way valves, the values only apply to the control passage.

##### $\Delta p_{stat}$ :

Line pressure behind the valve. This essentially corresponds to the idle pressure when the pump is switched off, caused for example by the fluid level in the system, increased pressure due to pressure tanks, steam pressure, etc.

For valves that close with pressure, the static pressure plus the pump pressure are used.

#### Disposal

When disposing of the product, observe the currently applicable local laws.

More information on materials can be found in the Declaration on materials and the environment for this product.

#### Characteristic for actuators with positioner

On actuator AVM 322S, AVM 234S or AVF 234S

Equal-percentage/linear/quadratic

Can be set using coding switch

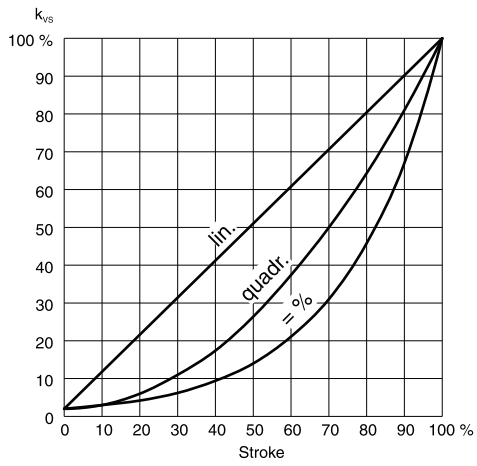

Dimension drawing

DN 65...100

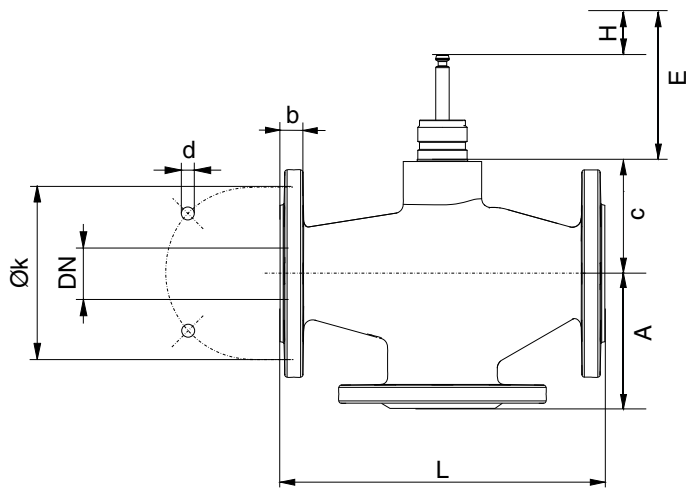

BQD	DN	A	c	L	H	k	d	b	E
065	65	120	102	290	20	130	4x14	16	93
080	80	130	112	310	20	150	4x19	18	93
100	100	150	127	350	40	170	4x19	18	113

Combinations

AVM 234

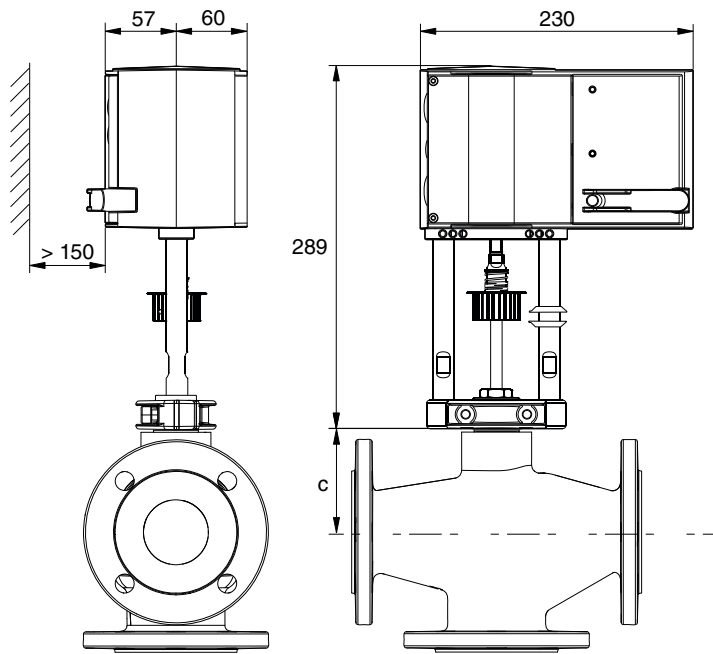

AVF 234

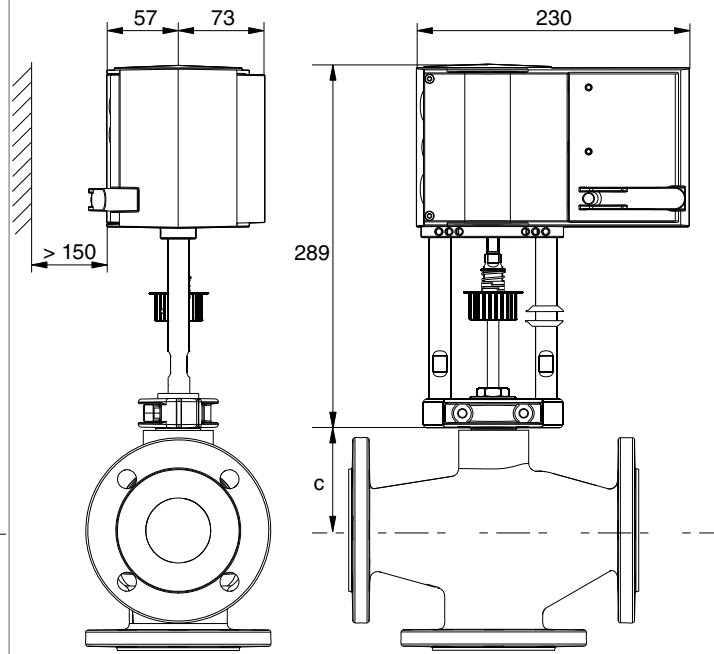

AVM 322(S)

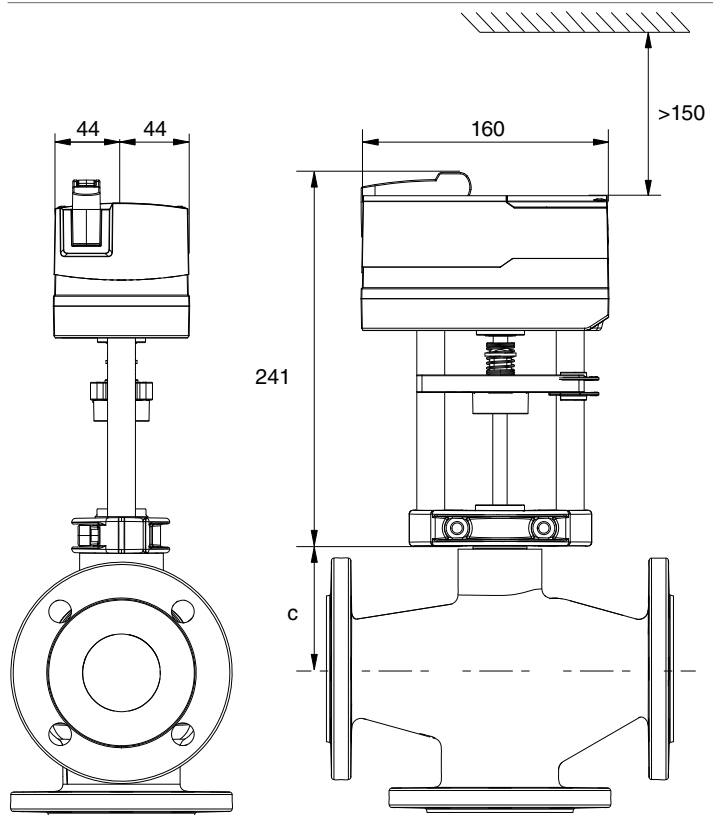



## Accessories

0378284 100  
0378284 102