

EY-RC 500: Room automation station, ecos500

How energy efficiency is improved

Powerful function modules in the ecos500 allow energy-optimised room control and the control of lights and blinds, and guarantee minimum energy consumption

Features

- Part of the SAUTER EY-modulo 5 system family
- Communication: BACnet/IP (EN ISO 16484-5)
- Programming/parameterisation via PC using CASE Suite (based on IEC 61131-3)
- Room automation station for up to four rooms or room segments
- Can be extended with up to sixteen ecoLink remote I/O modules
- Free arrangement of hardware
- The ecoUnit 3 (EY-RU 3**) and ecoUnit 1 (EY-RU 1**) room operating units enable individual adjustment of the room climate – mixed mode is possible
- Optimises energy consumption thanks to occupancy function, window contact monitoring, demand-controlled switching of fan speeds, control of lighting and window blinds, and time-dependent set-point specification
- Predictive control based on meteorological forecast data
- Time and calendar function
- Integration into the building management system via Ethernet/BACnet/IP data interface
- Control libraries

Technical data

Power supply		
Power supply		230 V~, ±10%, 50...60 Hz
Power consumption		≤ 34 VA (incl. 12 VA external)
Dissipated power		≤ 15 W
Battery (buffer: RTC/SRAM)		Lithium button-cell (CR2032), insertable
Ambient conditions		
Operating temperature		0...45 °C
Storage and transport temperature		-25...70 °C
Admissible ambient humidity		10...85% rh, no condensation
Inputs/Outputs		
Inputs	Universal inputs	8, Ni1000, Pt1000, 0...10 V, DI
	Digital inputs	4
Outputs	Relay	16 normally-open contacts (250 V~) Terminals 1 to 28
	Triac	8 (24 V~)
	Analogue	4, 0...10 V
Function		
Number of dynamic objects	BACnet data point objects	256 incl. HW
	Time programmes	32 (Schedule)
	Calendar	8 (Calendar)
	Alarms	16 (Notification Class)
	Historical data	16 (Trend Log) ≤ 2000 entries
	Control	32 (Loop)
	COV notifications	500
	Structured view	64 (Structured View)
	BACnet client links	200 (Peer-to-Peer)
	Number of BBMDs in BDT	32
Number of FDs in FDT	32	
Architecture		
Processor		32 bit, 200 MHz
SDRAM (synchronous dynamic RAM)		32 MB
SRAM (static RAM)		128 kB

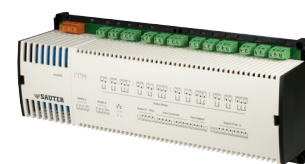

EY-RC500F001

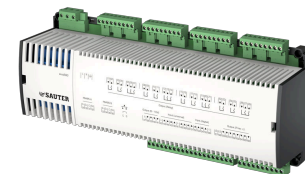

EY-RC500F002



Flash	16 MB
Operating system	Linux
Cycle time	100 ms
Application data	Via CASE Engine

Interfaces and communication

Ethernet network	2 × RJ-45 socket (2-port switch)
10/100 BASE-T(X)	10/100 Mbit/s
Communication protocols	BACnet/IP
Operating units	≤ 4 in total, EY-RU 3** RS-485 A EY-RU 1** via EY-EM 580 to RS-485 A
Extension interface	RS-485 B

Construction

Fitting	Top-hat rail/wall
Dimensions W x H x D	299 × 120 × 73 mm
Weight	1.6 kg

Standards and directives

Type of protection ¹⁾	IP 00 (EN 60529)
Protection class	I (EN 60730-1)
Environment class	3K3 (IEC 60721)
Mode of operation	Type 1 CI (EN 60730)
Software class A	EN 60730-1 Annexe H
CE conformity according to	EMC directive 2004/108/EC ²⁾ EN 61000-6-1, EN 61000-6-2, EN 61000-6-3, EN 61000-6-4
	Low-voltage directive 2006/95/EC EN 60730-1, EN 60730-2-9
Valid for eu.bac. devices EY-RC500F511, EY-RC500F521	Energy Performance of Buildings Directive 2010/31/EC EN 15500
	eu.bac licence no. 211169

Overview of types

Type	Description
EY-RC500F001	With screw terminals
EY-RC500F002	With plug-in connectors
EY-RC500F511	With screw terminals, eu.bac application for fan coil unit system – 4-pipe
EY-RC500F521	With screw terminals, eu.bac application for chilled-beam system

 On the EY-RC500F5** versions, it is not permitted to make any changes to the user program that have an influence on the control quality, otherwise the eu.bac certificate loses its validity

Accessories

Type	Description
0900240002	Terminal cover, 295 mm (2 pcs.)
0900240011	Wiring box, 295 mm (2 pcs.)

Description of operation

The ecos500 room automation station is a compact unit for energy-optimised room control by means of demand-controlled fan speed switching, window contact monitoring and the control of lights and blinds. This allows an individual room climate to be attained with minimum energy consumption.

The room automation station is based entirely on BACnet/IP communication.

The ecos 5 system family comprises a range of devices for room automation for the BACnet/IP system bus. The ecos500 is a freely programmable BACnet Building Controller (B-BC) for the automation of up to 4 rooms with the functions room climate, lighting and sunshade. The powerful programming environment CASE Suite and the available function libraries allow both standard tasks of room automation and complex projects with flexible room division, based on room segments, to be carried out efficiently.

¹⁾ IP 10 with terminal cover (accessory 090024002); IP 20 with wiring box (accessory 090024011)

²⁾ EN 61000-6-2: If it is mandatory to comply with the European standard, the power cables for the digital inputs (DI), analogue inputs and outputs (AI/AO) and the RS-485 cables must not exceed 30 metres in length

The ecos500 has a total of 40 inputs and outputs. Two RS-485 interfaces can be used to connect ecoUnit 3 room operating units, ecoLink remote I/O modules and an ecoMode580 EnOcean wireless interface. The wireless interface can be used to integrate the SAUTER ecoUnit 1 wireless room operating units as well as other standard EnOcean units.



Note:

More detailed information on BACnet functionality can be found in the PICS documentation.

Intended use

This product is only suitable for the purpose intended by the manufacturer, as described in the “Description of operation” section.

All related product documents must also be adhered to. Changing or converting the product is not admissible.

EY-RC500F511 with the eu.bac application “fan coil unit system – 4-pipe”

Key figures of eu.bac certification

Mode	Control accuracy
Heating	Approx. 0.2 K
Cooling	Approx. 0.3 K

The application has been certified with the following devices:

Type	Quantity	Description
EY-RC500F511	1	Room automation station with screw terminal
EY-RU346F001	1	ecos 5 operating unit, LCD, NTC sensor, dXs setpoint adjuster, 6 buttons
AXS215SF122	2	Continuous actuator for unit valves with stroke indicator
VCL025F200	2	2-way regulating valve (linear)

EY-RC500F521 with the eu.bac application “chilled-ceiling system”

Key figures of eu.bac certification

Mode	Control accuracy
Cooling	Approx. 0.1 K

The application has been certified with the following devices:

Type	Quantity	Description
EY-RC500F521	1	Room automation station with screw terminal
EY-RU346F001	1	ecos 5 operating unit, LCD, NTC sensor, dXs setpoint adjuster, 6 buttons
AXS215SF122	1	Continuous actuator for unit valves with stroke indicator
VCL025F200	1	2-way regulating valve (linear)

Engineering notes

The I/O mix of the ecos500 is designed for up to 4 typical rooms or 4 room segments, i.e. 4 room controllers are integrated in one device. During programming, a program is created that applies equally to all rooms/room segments. The possible number of segments is 1, 2 or 4.

Fitting and power supply

The ecos500 is a compact unit suitable for wall mounting or for DIN 43880 installation on a 35 mm top-hat rail. The plant devices are connected using screw terminals. The following conditions must be observed:

- Connection may only be performed when the system is disconnected from the electrical supply.
- The unit must be protected against contact.
- The max. available power at the LS terminals is 12 VA.
- The ground terminals are connected internally to the earth connection (PELV electrical circuits).
- External primary isolating facility.
- Protective earth is connected to the relevant terminal.

Cross-section of the wire: min. 0.8 mm² (AWG 18), max. 2.5 mm² (AWG 13), taking standards and national installation regulations into account.

For communication, there are two RJ45 network connections with switch functionality that can be used to switch the ecos500s in a sequence. When establishing the network topology, the Ethernet network standards are to be taken into account.

The communication wiring must be carried out correctly and in accordance with the standards EN 50174-1, -2 and -3. Communication wires must be kept at a distance from other live wires. Special standards such as IEC/EN 61508, IEC/EN 61511, IEC/EN 61131-1 and -2 were not taken into account. Local requirements regarding installation, usage, access, access rights, accident prevention, safety, dismantling and disposal must be taken into account. Furthermore, the installation standards EN 50178, 50310, 50110, 50274, 61140 and similar must be observed. For further information, see the fitting instructions P100002325.

Wiring box

The wiring box is used for professional connection of supply and control lines with cable fixing clips. When the cover is in place, it provides the IP 20 degree of protection together with the ecos500.

Wiring box

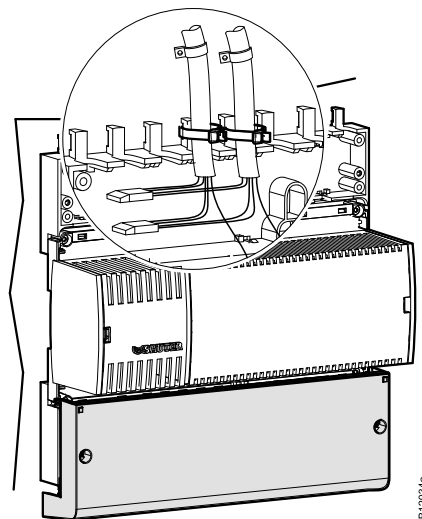

Wiring rules

The feedback cables for the Ni1000 and Pt1000 sensors must be separated from the other inputs and outputs (DI 1.2 mA, 0...20 mA), i.e. separate GND terminals (\perp) must be used.

Inputs/outputs

The ecos500 has 40 inputs and outputs with the following functionalities:

Universal inputs

Number of inputs	8 (UI)
Type of inputs (software coding)	Ni1000 (DIN 43760) Pt1000 (EN 60751) Voltage measurement (U) Current measurement (I) (with external resistance) Resistance measurement Digital input (DI)
Protection against external voltage	
Ni/Pt/U/DI	± 30 V/24 V~ (without destruction)
Scan rate	100 ms (digital values) 500 ms (analogue inputs)
Resolution	> 14 bits
Measuring ranges	
Voltage (U)	0 (2)...10 V, 0 (0.2)...1 V
Current (I) (via ext. R)	0 (4)...20 mA
Resistance	200...2500 Ω
Temperature Ni/Pt1000	-50...+150 °C

Digital input	Potential-free contacts with ground connection opto-coupler, transistor (open collector) I_{out} : • ~1.2 mA for UI • ~1.2 mA for DI
Meter	Max. 3 Hz (100 ms scan rate)

Temperature measurement (Ni/Pt)

The Ni/Pt1000 sensors are connected using two wires between one of the input terminals for universal inputs (channel 26...33) and a ground terminal. The inputs require no calibration and can be used directly. Line resistance of 2 Ω is pre-compensated as standard. With the correct line resistance of 2 Ω (cable cross-section 1.5 mm²), the power cable (wire) may be no more than 85 m. Larger line resistances can be compensated by the software. The measurement current is pulsed to ensure that the sensor is not heated (I_{meas} ~0.3 mA).

Voltage measurement (U)

The voltage to be measured is connected between an input terminal for universal inputs (channel 26...33) and a ground terminal. The signal must be potential-free. The measuring ranges with or without offset 0 (0,2)...1 V or 0 (2)...10 V are selected through the software. The internal resistance R_i of the input (load) is 9 M Ω .

Current measurement (I)

A current measurement is possible via external resistance (e.g. 50 Ω). The current to be measured is connected on one of the two input terminals for universal inputs (channel 26...33) and a ground terminal parallel to the resistance. The current signal must be potential-free.

If other channels experience malfunctions: See *Wiring rules*.

Resistance measurement

The ecos500 can measure resistive loads between 200 and 2500 Ω . The measurement takes place with respect to ground. Higher resistance values can be scaled to approx. 2500 Ω by parallel switching of an additional fixed resistance. A linearisation may be needed in the user program.

Digital inputs (DI with UI)

The ecos500 also records binary information with the universal inputs. The information (alarm/status) is connected between an input terminal and the ground (channel 26...33). The station applies a voltage of approximately 13 V to the terminal. If a contact is open, this usually corresponds to an INACTIVE state (bit = 0). If a contact is closed, there is an ACTIVE state (bit = 1) and 0 V is applied, giving a current of approximately ~1.2 mA.

Every input can be defined individually as an alarm or a status input by setting software parameters. At the universal inputs, counter inputs of potential-free contacts, opto-couplers or transistors with an open collector can be connected. The maximum pulse frequency may be up to 3 Hz.

Digital inputs (DI fixed)

Number of inputs	4 (DI fixed)
Type of inputs	Potential-free contacts with ground connection opto-coupler, transistor (open collector)
Meter	\leq 3 Hz (100 ms scan rate)
Protection against external voltage	\pm 30 V/24 V~ (without destruction)
Maximum output current	~1.2 mA with respect to ground
Scan rate	100 ms

The binary information is connected between one of the input terminals (channels 38...41) and the ground. The station applies a voltage of approximately 13 V to the terminal. If a contact is open, this usually (NORMAL) corresponds to an INACTIVE state (bit = 0). If a contact is closed, there is an ACTIVE state (bit = 1) and 0 V is applied, giving a current of max. 2 mA.

Every input can be defined individually as an alarm or a status input by setting software parameters. At the digital inputs, counter outputs of potential-free contacts, opto-couplers or transistors with an open collector can be connected. The maximum pulse frequency may be up to 3 Hz.

Operating units

Number of units	≤ 4 operating units in total, EY-RU 3** and/or EY-RU 1**
Interface	RS-485 A

The EY-RU 3** operating units are connected directly to the serial RS-485 A interface with a 4-core, twisted connecting cable. With a minimum cable cross-section of 0.5 mm², the line may be up to 100 m long. The communication protocol is SLC.

The EY-RU 1** EnOcean wireless operating units are connected via an EY-EM 580 bi-directional wireless interface to the ecos500, which is also connected to the series RS-485 A interface with a 4-core connection. The line length may be up to 100 m. The communication protocol is SLC.

Up to 4 operating units may be connected to each ecos500. Mixed mode between wired operating units (EY-RU 3**) and wireless room operating units (EY-RU 1**) is possible.

To avoid overloading the supply to the RS-485 A interface, a connected EY-EM 580 wireless interface may only be connected to a maximum of two EY-RU 3**. According to standard, the connection of several wireless interfaces is not possible.

Extension interface

Interface	RS-485 B
-----------	----------

This interface of the ecos500 is intended for connecting ecoLink modules.

A 4-core twisted cable is to be used to connect to the serial RS-485 B interface. The max. admissible bus length depends on the cable type used and the correct termination with terminating resistors. For Ethernet CAT-5 cables, as well as IYST-Y cables, a bus length of up to 500 m is possible. Bus cabling must follow line topology. Star, tree or branch topologies are not recommended. On the ecos500 room automation station, a 3-core bus connection to the RS-485 B interface is made. Observe the correct polarity. The devices do not have internal terminating resistors.

Digital outputs (relay)

Number of outputs	16 (DO)
Type of outputs	Relay, normally-open contacts (0-1)
Load on outputs	See table <i>Technical specifications</i>
Switching frequency	3 × 10 ⁵ cycles
Switching voltage	24...250 V



Note:

The following are not admissible: mixed connections for power circuits, different phases (L1, L2, L3) or different voltage ranges (low voltage).

The actuator to be switched is connected directly to the relay terminals (channel 0...15).

The digital outputs can be defined for single- or multi-layered functions. Real feedback is only possible via digital inputs (BACnet COMMAND FAILURE)

Digital outputs (Triac)

Number of outputs	8 (DO)
Type of outputs	Triac, normally-open contacts (0-1)
Load on outputs	24 V~/0.5 A (resistive load)

The actuator to be switched (e.g. thermal actuator) is connected directly to the Triac terminals (channel 18...25). The Triac is earthed.

The Triac outputs can be defined for single- or multi-layered functions. Real feedback is only possible via digital inputs (BACnet COMMAND FAILURE)

For thermal actuators, the power supply can be taken from the LS terminals. The maximum available current can be seen in the table *ecos500 load calculation*.

Analogue outputs

Number of outputs	4 (AO)
Type of outputs	4x 0(2)...10 V sinkable from 1 V
Load	≤ 2 mA
Update rate	100 ms
Resolution	13 bits

The output voltage is taken from between the correct output terminal (channel 34...37) and a ground terminal. The outputs are designed as push-pull outputs with active sink capability. Every output can be subjected to a load of 2 mA. The total of all analogue output currents should not exceed 8 mA to ensure safe operation.

The analogue output of the ecos500 is short circuit-proof and grounded but not protected against external voltages. Permanent short-circuiting of multiple outputs leads to their thermal destruction.

There is still protection against static discharges.

Technical specifications of the inputs and outputs

Universal input	Measuring range	Resolution	Accuracy	
			Measuring span	plus measured value
Ni/Pt1000	-50...+150 °C	< 0.05 K	±0.5%	0.5%
U (0/0.2...1 V)	0.02...1.05 V	< 0.1 mV	±0.5%	0.5%
U (0/2...10 V)	0.15...10.2 V	< 1 mV	±0.5%	0.5%
R	200...2500 Ω	< 0.1 Ω	±1%	1%

Relay outputs

Terminals	Continuous load per switching contact (max. ³⁾)	Start-up current	Example of intended use
1-2, 8-9, 15-16, 22-23	5 A	80 A (20 ms)	Electric heating
3-4, 10-11, 17-18, 24-25	5 A	80 A (20 ms)	Lights or fan (1-speed or, if 3-speed, 3rd speed)
5-7, 12-14, 19-21, 26-28	1 A	30 A (20 ms)	Fan (2-speed or, if 3-speed, 1st and 2nd speed) or window blind, max. 100 VA rated motor power/5 m

Triac outputs

Terminals	Continuous load (max.)	Example of intended use
59-66	0.5 A	Thermal actuators: A Triac can switch up to 0.5 A. If the power for thermal actuators is supplied from the LS terminal, the total of all currents simultaneously switched via the Triacs may be up to 0.5 A.

Analogue output	Range of adjustment	Resolution	Accuracy
AO (0/2...10 V, ≤ 2 mA)	0.01...10.2 V	< 2 mV	1% of the end value

Binary input (O-I)	Universal input (UI)	Digital input (DI)
Switching threshold inactive	> 3 V	> 8 V
Switching threshold active	< 1.5 V	< 1.5 V
Switching hysteresis	> 0.4 V	> 0.4 V

Actuation of constant drives

An analogue output (10 V_r) can be permanently loaded with up to 2 mA. This results in a load of ≥ 5000 Ω.

Sizing/loading of the internal transformer

The transformer installed in the ecos500 supplies the electronics, provides actuation current for the internal relays and provides 24 V_r for thermal actuators at the LS terminals.

The circuitry of the ecos500 may not overload the internal transformer. The table *ecos500 load calculation* can be used for the calculation.

Expansion of an external transformer

If the maximum admissible current of the internal transformer is exceeded, an external transformer can be used to provide additional capacity. This takes over the supply for the thermal actuators from the external transformer. The Triac may be operated with a continuous load of max. 0.5 A.

³⁾ The following are not admissible: mixed connections for power circuits, different phases (L1, L2, L3) or different voltage ranges (low voltage).

Wiring diagram: External transformer

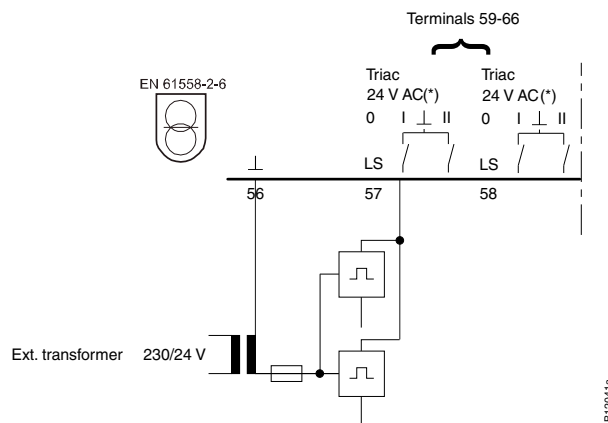

Parallel operation of more than 4 thermal actuators

If higher currents are required, a semiconductor relay can be added. The drives are also supplied by an external transformer. The number of drives is limited by the output of the semiconductor relay.

Example:

24...280 V~, 8 A without heat sink at 230 V~, control voltage 18...36 V~

Wiring diagram: Parallel operation

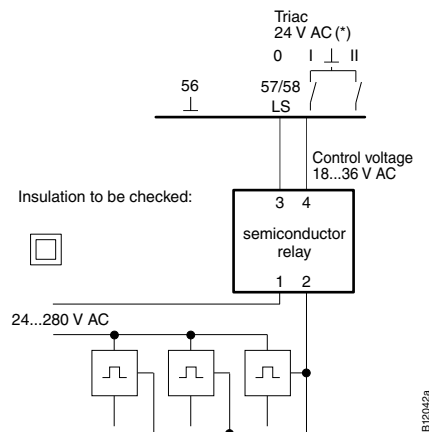

ecos500 load calculation

The ecos500 is designed for 4 rooms/segments, each with the following application:

- 1x electric heating,
- 1x lamp,
- 1x window blind UP/DOWN and
- 2x thermal actuator (heating/cooling).

Other combinations are possible, e.g. 1x lamp and 3-speed fan, etc.

The internal transformer is sized for this application.

If the ecos500 is used with a different allocation, it must be ensured that the transformer is not overloaded.

The table below can be used to calculate the load of an allocation.

ecos500 load calculation

Terminal no.	Type	Inrush currents Max.	Continuous load (A) Max.	Current load (mA) Internal transformer	Application: Continuous load (mA) Internal transformer
01	IN				
02	Relay	80 A (Inrush)	5	40	
03	IN				
04	Relay	80 A (Inrush)	5	40	
05	IN				
06	Relay	30 A	1	20	
07	Relay			20	

Terminal no.	Type	Inrush currents Max.	Continuous load (A) Max.	Current load (mA) Internal transformer	Application: Continuous load (mA) Internal transformer
08	IN				
09	Relay	80 A (Inrush)	5	40	
10	IN				
11	Relay	80 A (Inrush)	5	40	
12	IN				
13	Relay	30 A	1	20	
14	Relay			20	
15	IN				
16	Relay	80 A (Inrush)	5	40	
17	IN				
18	Relay	80 A (Inrush)	5	40	
19	IN				
20	Relay	30 A	1	20	
21	Relay			20	
22	IN				
23	Relay	80 A (Inrush)	5	40	
24	IN				
25	Relay	80 A (Inrush)	5	40	
26	IN				
27	Relay	30 A	1	20	
28	Relay			20	
57	LS_out		12 VA (=0.5 A) in total		
58	LS_out				
59	Triac 24 V~			125 ⁴⁾	
60	Triac 24 V~			125	
61	Triac 24 V~			125	
62	Triac 24 V~			125	
63	Triac 24 V~			125	
64	Triac 24 V~			125	
65	Triac 24 V~			125	
66	Triac 24 V~			125	
				Sum	
					Permanent current, max. 1000 mA

Ethernet system bus

The ecos500 stations have 2 Ethernet connections. These have the functionality of a switch. The wiring must be performed in accordance with the general rules for Ethernet/IP networks.

Commissioning

The work must always be carried out when the system is disconnected from the electrical supply. Protective ESD measures must be taken before any interventions.

Programming and parameterisation

The complete user program (Engine Plan) and the different parameterisations (BACnet objects, images for moduWeb etc.) are created using CASE Suite. Up to 256 BACnet data points incl. hardware inputs and outputs can be used.

Every ecos500 must be configured for communication in an Ethernet network. All settings such as IP address, subnet mask, gateway and instance number (DOI) are parameterised via CASE Sun. Automatic configuration via DHCP servers is also possible.

In order to be able to identify the room automation station in a network visually, the CASE Sun commissioning tool can be used to put the run/fault LED in flashing mode.

The user program can be loaded from any point in the IP network with CASE Suite. Flashing red LED indicators show that there is an active download. The data is written to the flash memory and is held even if there is a power failure. This ensures a high degree of security with regard to data loss.

⁴⁾ e.g. AXT111F202

The inputs and outputs can be parameterised by the user program and used freely for control and regulation tasks.

Initialisation

An initialisation of the AS can be carried out with CASE Suite before the download.

Firmware/update

The room automation station is delivered with a current version of the firmware. If a newer version of the firmware becomes available before installation and commissioning, the ecos500 can be updated directly via the network using CASE Sun. Flashing red LED indicators show that there is an active update.

Before commissioning of a room automation station, you must check the firmware version and, if necessary, carry out an update.

Internal clock

A battery-buffered real time clock (RTC) is integrated into the ecos500 for the time programmes. The date, time and time zone are set in the ecos500 when loading the user data.

The time, date and time zone can be set manually, for example using the BACnet browser.

The BACnet services "DM-TS-B" and "DM-UTC-B" are used to synchronise the time and date automatically if a BACnet time server is specified accordingly (e.g. novaPro Open).

The summer time setting (daylight saving) is activated in the AS network properties of the automation station (CASE Engine) by default and includes all the room automation stations integrated into the same network.

Time programmes, calendar

The BACnet functionality allows up to 32 time programmes (schedule) and up to 8 calendar objects (calendar) to be created in the ecos500.

Battery, data buffering

A pluggable lithium button-cell battery ensures that the RTC for time programmes (schedule/calendar) and data such as counters, e.g. adaptive control algorithms, are retained in the memory (SRAM), even if there is a power failure.

The battery voltage is not monitored by the ecos500.

Technical data for the battery

Type (standard)	Lithium button-cell CR2032
Nominal voltage	3 V
Capacity	210 mAh
Dimensions	20 × 3.2 mm

The user data from CASE Engine and modified user data (e.g. modified by BACnet client) is permanently stored in the flash memory and does not require a battery buffer.

However, it is advisable to safeguard user data (CASE Engine) and modified user data also by means of a backup (e.g. BACnet DM BR).

Behaviour in case of mains failure

There are different types of power failure:

• Micro-interruptions

Micro-interruptions generally last a number of micro-seconds (0...999 µs). These interruptions are bridged without any shutdowns or other consequences. The system continues to run in normal mode.

• Normal interruptions

These interruptions generally last a number of seconds or minutes. For the ecos500, this means a correct shutdown and switching back on correctly according to priority when grid voltage returns. The ecos500 performs this correct shutdown and start-up automatically.

For BACnet objects, this means:

- The "Notification Class Recipient List" remains and the clients automatically receive the event and alarm information without logging in again.
- One's own COV messages remain.
- The COV subscriptions on other stations are logged in again automatically.
- Connections between room automation stations (AS-AS) are updated again (re-subscription).
- When the grid returns, the room automation station will check the consistency of the data and will automatically restart communication.

Extension options

SLC interfaces can be used to enhance the ecos500 with various components.

Note on application

The use of occupancy detectors and window contacts can improve energy efficiency. The signals can be connected both to the digital inputs (channel 38-41/terminal 52-55) and to the universal inputs (channel 26-33/terminal 43-51).

Additional information

Fitting instructions	P100002325
Declaration on materials and the environment	MD 94.108
Dimension drawing	M11415
Connection diagram	A10603
	A10681
	A10682

Disposal

When disposing of the product, observe the currently applicable local laws.

More information on materials can be found in the Declaration on materials and the environment for this product.

Channel and terminal assignment - ecos500 for 1 room/segment

Description	Terminals Room/segment 1			Field devices (Application)
	Channel	Signal	Common	Occupancy
Digital output (relay 0-I)	00	02	01	
	01	04	03	
	02	06	05	
	03	07		
	04	09	08	
	05	11	10	
	06	13	12	
	07	14		
	08	16	15	
	09	18	17	
	10	20	19	
	11	21		
	12	23	22	
	13	25	24	
	14	27	26	
15	28			
RS-485 A		29, 30, 31, 32		
RS-485 B		33, 34, 35, 36		
			GND	
Analogue output (0...10 V)	34	38	37	
	35	39		
	36	40		
	37	41		
Universal input (Ni/Pt1000/U/DI)	26	43	42	
	27	44		
	28	45		
	29	46		
	30	48	47	
	31	49		
	32	50		
	33	51		

Description		Terminals		Field devices (Application)
		Room/segment 1		
Digital input (DI)	38	52	56	
	39	53		
	40	54		
	41	55		
Voltage output LS (24 V~)		57		
		58		
Digital output (Triac 0-I)	18	59		
	19	60		
	20	61		
	21	62		
	22	63		
	23	64		
	24	65		
	25	66		

Channel and terminal assignment – ecos500 for 2 rooms/segments (1 device with 2 functionally identical segments [2 virtual ecos])

Description		Terminals				Field devices (Application)	Room/segment		
		Room/segment 1		Room/segment 2			Occupancy	1	2
		Channel	Signal	Common	Signal				
Digital output (relay 0-I)	00	02	01	16	15				
	01	04	03	18	17				
	02	06	05	20	19				
	03	07		21					
	10	09	08	23	22				
	11	11	10	25	24				
	12	13	12	27	26				
	13	14		28					
RS-485 A	---	29, 30, 31, 32							
RS-485 B	---	33, 34, 35, 36							
			GND		GND				
Analogue output (0...10 V)	06	38	37	40	37				
	16	39		41					
Universal input (Ni/Pt1000/U/DI)	07	43	42	48	42				
	08	44		49					
	17	45	47	50	47				
	18	46		51					
Digital input (DI)	09	52	56	54	56				
	19	53		55					
Voltage output LS (24 V~)	---	57, 58							
Digital output (Triac 0-I)	04	59		63					
	05	60		64					
	14	61		65					
	15	62		66					

Channel and terminal assignment – ecos500 for 4 rooms/segments (1 device with 4 functionally identical segments [4 virtual ecos])

Description		Terminals							
		Room/segment 1		Room/segment 2		Room/segment 3		Room/segment 4	
		Chan- nel	Signal	Com- mon	Signal	Com- mon	Signal	Com- mon	Signal
Digital output (relay 0-I)	00	02	01	09	08	16	15	23	22
	01	04	03	11	10	18	17	25	24

Description	Terminals								
	02	06	05	13	12	20	19	27	26
	03	07		14		21		28	
RS-485 A	--- 29, 30, 31, 32								
RS-485 B	--- 33, 34, 35, 36								
			GND		GND		GND		GND
Analogue output (0...10 V)	06	38	37	39	37	40	37	41	37
Universal input (Ni/Pt1000/U/DI)	07	43	42	45	42	48	42	50	42
	08	44	47	46	47	49	47	51	47
Digital input (DI)	09	52	56	53	56	54	56	55	56
Voltage output LS (24 V~)	--- 57, 58								
Digital output (Triac 0-I)	04	59		61		63		65	
	05	60		62		64		66	

Connection diagram

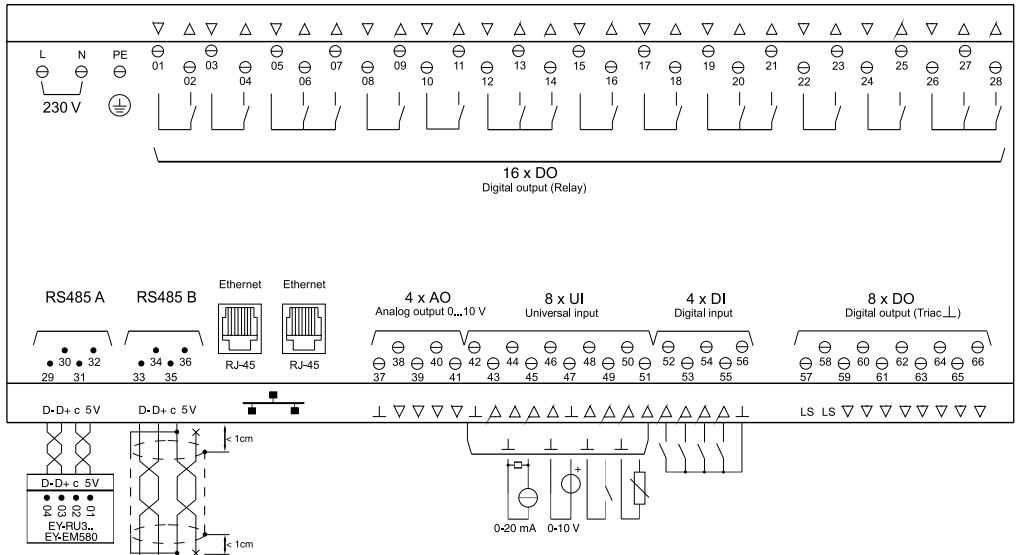

Connection diagram of EY-RC500F511: Application for fan coil unit system, 4-pipe

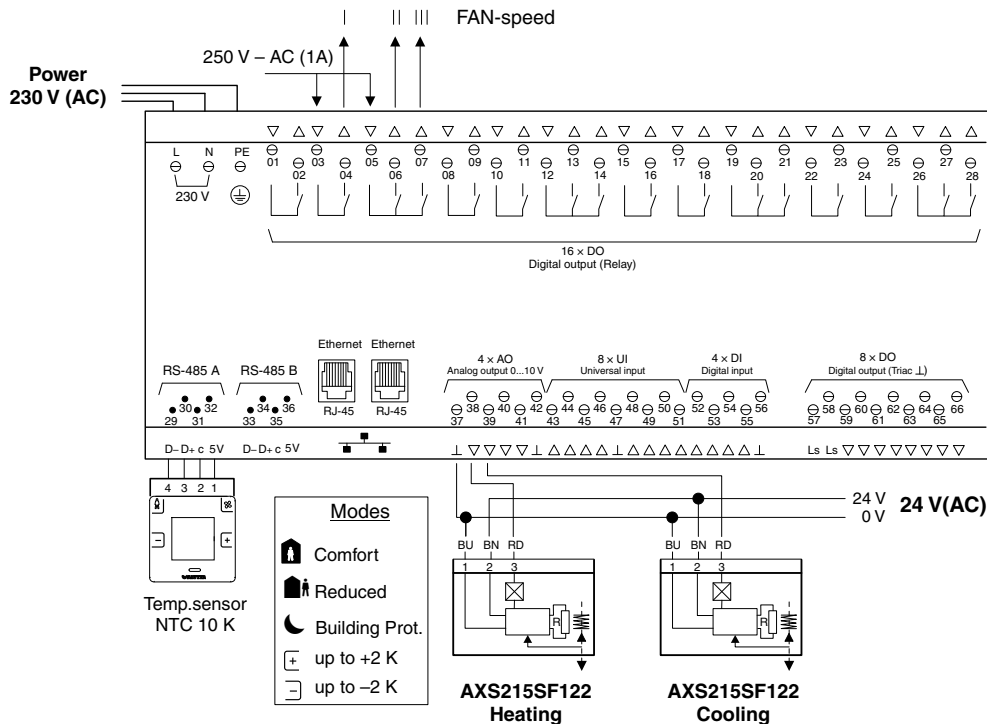

Connection diagram of EY-RC500F521: Application for chilled-ceiling system

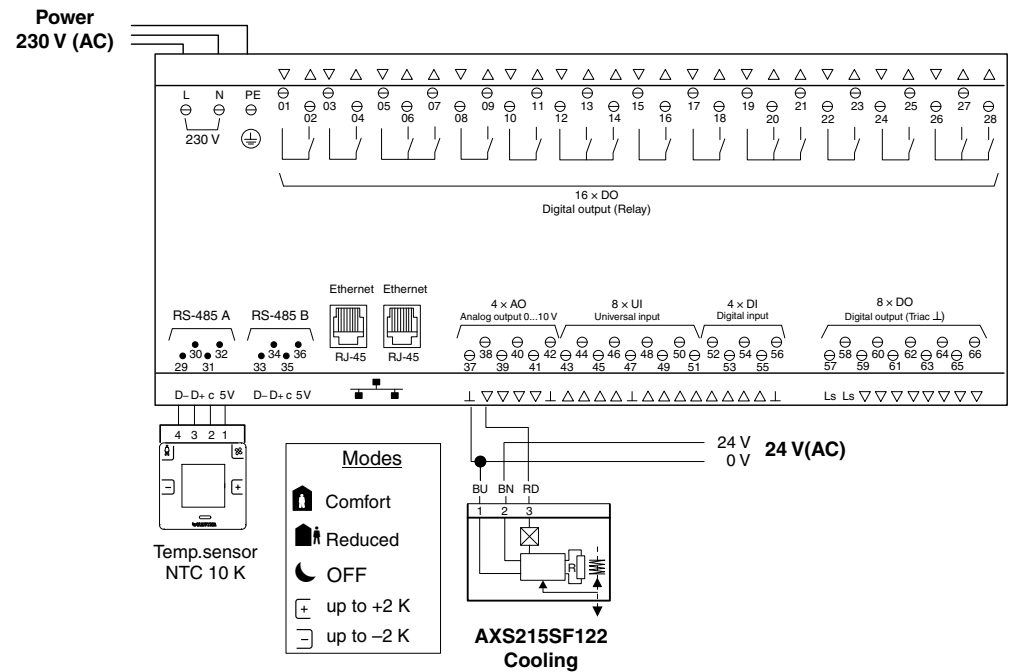

A10822a

Dimension drawing

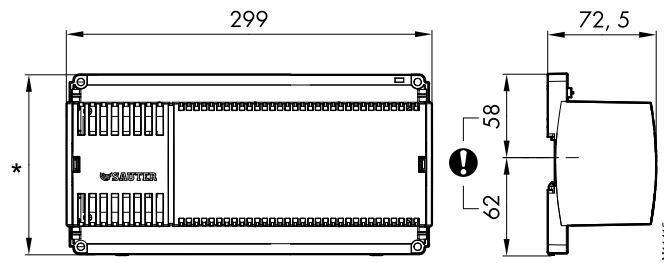

- 1) 120 mm: EY-RC50*F001, EY-RC500F511, EY-RC500F521
- 1) 133 mm: EY-RC500F002