

EGH 102: Dew-point monitor and transducer

How energy efficiency is improved

Effective protection against humidity damage and excessive cooling.

Areas of application

Protection against dew formation on chilled beams. Control system for a regulating unit using a holding relay, which interrupts the flow of cold water or raises the temperature of the cooling water.

Features

- Measurement is effected by a spring-loaded dew-point sensor
- Active measured value acquisition
- Versions with external sensor

Technical description

- Housing made of pure-white, flame-retardant thermoplastic (RAL 9010)
- Holding relay with change-over contact
- Screw terminals for wire of up to 1,5 mm²
- Cable inlet for Pg 11
- Strap retainer for 10 to 100 mm ø pipe and heat-conducting paste are included in supply



T08787

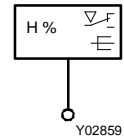

Type	Switching point %rh	Sensor	Measuring range %rh	Power supply	Weight kg
EGH 102 F001	95 ± 4	on housing	70...85	24 V~/=	0,1
EGH 102 F101	95 ± 4	with cable	70...85	24 V~/=	0,1

Power supply 24 V~/=	± 20%	Exposure to dew	max. 30 min
Switching difference	fixed, approx. 5 %rh	Ambient temperature	5...60 °C
Power consumption	max. 1 VA	Degree of protection	IP 40 (EN 60529)
Change-over contacts 1)	1A, 24 V~/=	Wiring diagram	A09353
Output signal approx. 70...85 %rh	0...10 V, load > 10 kΩ	Dimension drawing F001	M07664
Response time in still air:-		F101	M10454
80 to 99 %rh	max. 3 min	Fitting instructions F001	MV 505732
99 to 80 %rh	max. 3 min	F101	MV 506037

1) When driving relays, contactors etc. with $\cos \varphi < 0,3$, the use of an RC section in parallel to the coil is recommended. This reduces pitting of the contacts and prevents high-frequency interference impulses.

Operation

The resistance of the dew-point sensor rises in accordance with the relative humidity. The resistance value is evaluated with the aid of the electronics unit and then (via a holding relay) used to control the change-over contacts. When power is applied, contacts 4-6 close as soon as the switching point is reached or exceeded. At the same time, contacts 4-5 open. If the switching point is undercut by the amount of the switching difference, contacts 4-6 open and contacts 4-5 close. In addition, there is an analogue output signal (Pin 3) available. If no power is applied, contacts 4-6 are closed and contacts 4-5 are open.

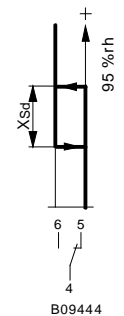

Engineering and fitting notes

The monitor should be fitted to the supply pipe at its coldest place: the surface of the pipe should be rendered clean and bare, the heat-conducting paste applied sparingly, and the sensor fixed by tightening the strap (snap-shut mechanism).

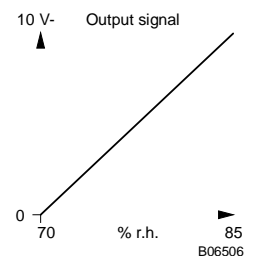

Wiring diagram

EGH 102 F001/F101

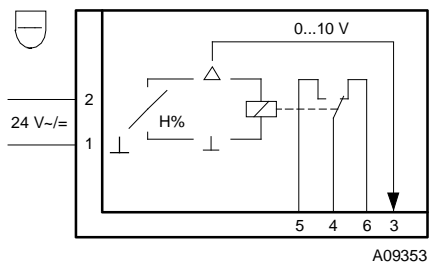

Dimension drawing

EGH 102 F101

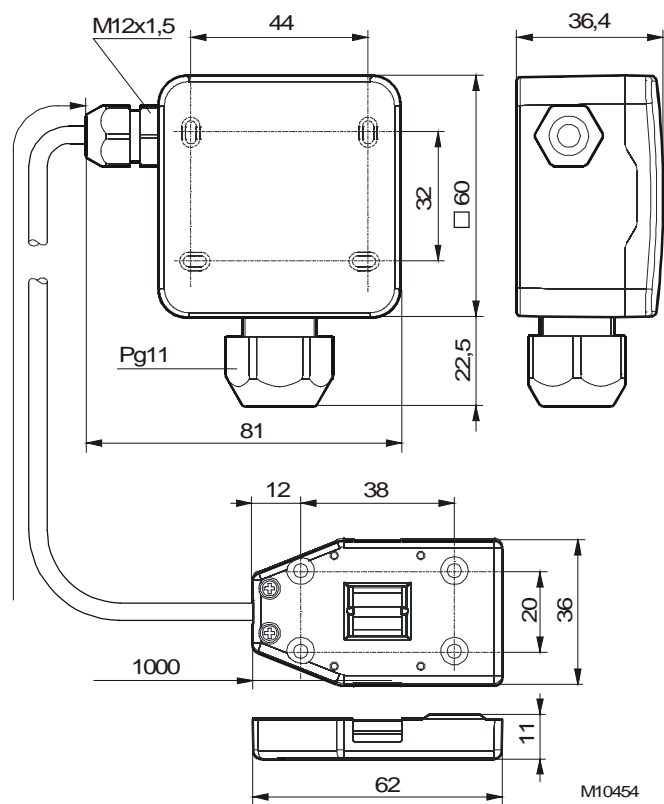

EGH 102 F001

