

AKF 112, 113: Rotary drive with spring return for control ball valves

How energy efficiency is improved

Torque related cut-off for efficient energy use.

Areas of application

For operating 2-way and 3-way control ball valves. For controllers with switching output (2-point or 3-point controller).

Characteristics

- Return to original position in the event of power failure or activation of a safety device
- Electronic torque-dependent shut-off using stops in the device
- Direction of rotation changed by installing the other way round

Technical description

- Two-piece housing made from cast light alloy with motor, gearbox, return spring and control electronics
- Also supplied: Installation kit for fitting to ball valves of type VKR and BKR, hex spanner for manual adjustment or spring winding, and position indication
- Connecting cable 0,9 m long, 0,75 mm², fixed to housing



T10649



Y01994

Type	Running time for 90° in s		Control function	Voltage	Weight
	Motor	Spring			
AKF 112 F120	90	15	2-point	230 V~	1,2
AKF 112 F122	90	15	2-point	24 V~ / 24 to 48 V=	1,2
AKF 113 F122	90	15	3-point	24 V~ / 24 to 48 V=	1,2

Supply voltage	230 V~ ± 10%, 50 to 60 Hz	Protection class See installation instructions	IP 42 in acc.with EN 60529
	24 V~ ± 20%, 50 to 60 Hz		IP 54
	24 to 48 V= ± 20%		
Power consumption		Protection class	230 V II in acc.with IEC 60730
AKF 112 F120	4,5 W 7,0 VA	24 V	III in acc.with IEC 60730
AKF 112 F122	3,5 W 5,0 VA		
AKF 113 F122	3,5 W 5,0 VA	Connection diagram	2 pt A05769
			3 pt A05770
Torque/holding torque	7 Nm	Dimension drawing	M10504
Rotation angle	max. 95°	Fitting instructions	P100002659
Perm. ambient temperature	-32 to 55 °C	Declaration on materials and the environment	MD 51.372
Perm. ambient humidity	5...95% rF		

Accessories

0510240 001 Mounting kit for ball valves VKR/BKR as spare part and as accessory for rotary drives ASF 112 and 113 from index B, MV P100002479

Function

2-point version:

After the voltage has been applied, the actuator that is being operated is controlled in the 90° position direction until the force-dependent shut-off occurs (scale on driver, max. rotating angle 95°). The gearbox is stopped by the brushless DC motor and blocked when this occurs. If the power fails or is switched off, the motor releases the gearbox so that the coupling socket is rotated back to the 0° position by the spring.

3-point version: the driver rotates itself from 0° to 90° when the voltage is applied to connection 2 (cable = violet) and from 90° to 0° when the voltage is applied to connection 3 (cable = orange). The drive stops in the centre position of the 3-point controller. If the power fails or the equipment is switched off by a safety device at connection 21 (cable = red) the gearbox is released, meaning that the coupling socket is turned back to the 0° position by the spring. The torque-dependent shut-off is actuated in both final positions (flap stop, stop due to rotating angle limit, maximum rotation angle of 95° reached) or in the event of an overload (no limit switches).

Engineering and fitting notes

The electronic system allows several control ball valves with different torques to operate in parallel. However, it must be ensured that the operating voltage is within the required tolerance. The drive can be installed in any position, but must not be suspended. It can be directly fitted to control ball valves of type VKR and BKR, and is secured using the installation kit.

No auxiliary relays or potentiometers can be retrofitted.

The rotation angle can be limited to a range of 0° to 90° in steps of 5°.

Attention! The housing must not be opened, risk of injury from re-adjusting spring.

Outdoor installation. We recommend that the equipment is provided with additional protection from the weather if it is installed outside.

Further information

The two-piece housing part (must not be opened) contains a brushless DC motor, the control electronics, a maintenance-free non-blocking gearbox, a re-adjusting spring and (230 V version only) a transformer. Right-handed or left-handed rotation is determined by appropriate positioning of the actuator on the control ball valves (change of direction of rotation of safety function).

The drive can be rotated to any position using the provided hex spanner and locked in position (see MV 505820). The gearbox is released again by means of mechanical unlocking or applying the operating voltage.

Power consumption:

Type	Running time s	Condition	active power P W	apparent power S VA
AKF 112 F120	90	Operation	4,5	7,0
		Stationary	3,5	3,5
AKF 112 F122	90	Operation	3,5	5,0
		Stationary	2,0	2,0
AKF 113 F122	90	Operation	3,5	5,0
		Stationary	2,0	2,0

CE conformity

EMC directive 2004/108/EC
EN 61000-6-2
EN 61000-6-3

For AKF 112 F120 only:
Low voltage directive 2006/95/EC
EN 60730-1
EN 60730-2-14
Overvoltage category III
Pollution level II

Connection diagrams

AKF 112 (2 pt)

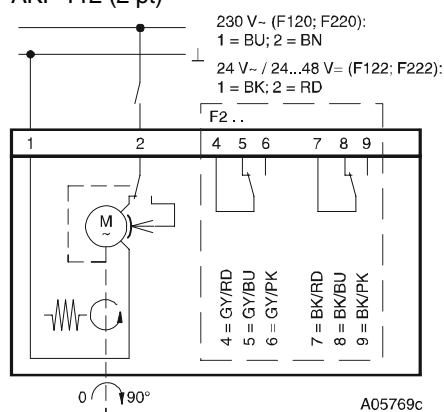

AKF 113 (3 pt)

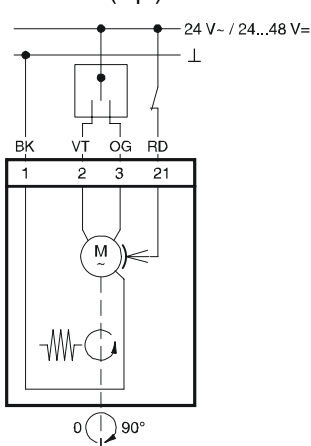

Dimension drawing

