

## VKR: 2-way ball valve with female thread, PN 40

### How energy efficiency is improved

Precision control and working without losses through leakage means efficiency.

### Areas of application

Control ball valve for continuous control of cold water, hot water or air in closed networks <sup>1)</sup>. Water quality as per VDI 2035, the use of strainers is recommended. Together with actuators AKM 105, 115(S) and AKF 112, 113(S) as regulating unit.

### Features

- Nominal pressure 40 bar <sup>3)</sup>
- Nominal diameter DN15 to DN50
- Equal percentage ball valve characteristic, integrated directly into ball
- Characteristic can be set to linear or quadratic with SUT rotary drive
- Spindle with large sliding surface and PTFE glide ring
- High control ratio of 500:1
- Low torque thanks to collar with O-ring bearing

### Technical description

- Ball valve with female thread as per ISO 7/1 Rp or NPT
- Body made of DZR (dezincification resistant) cast brass
- Axle made of DZR brass
- Ball made of DZR brass, chrome-plated and polished surface
- Axle seal with double O-ring made of EPDM
- Strainer and screw fitting available as accessories



T10647

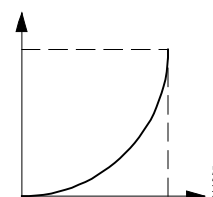

Equal-percentage characteristic curve

Type ISO 7/1 Rp	Type NPT	Nom. Diam. DN	Connection ISO 7/1 Rp	kvs Value m³/h	Weight kg
VKR 015 F350-FF	VKR 015 F350-UU	15	Rp 1/2"	1	0,29
VKR 015 F340-FF	VKR 015 F340-UU	15	Rp 1/2"	1,6	0,29
VKR 015 F330-FF	VKR 015 F330-UU	15	Rp 1/2"	2,5	0,29
VKR 015 F320-FF	VKR 015 F320-UU	15	Rp 1/2"	4	0,29
VKR 015 F310-FF	VKR 015 F310-UU	15	Rp 1/2"	6,3	0,29
VKR 015 F300-FF	VKR 015 F300-UU	15	Rp 1/2"	10	0,29
VKR 020 F320-FF	VKR 020 F320-UU	20	Rp 3/4"	4	0,32
VKR 020 F310-FF	VKR 020 F310-UU	20	Rp 3/4"	6,3	0,32
VKR 020 F300-FF	VKR 020 F300-UU	20	Rp 3/4"	10	0,32
VKR 025 F320-FF	VKR 025 F320-UU	25	Rp 1"	6,3	0,49
VKR 025 F310-FF	VKR 025 F310-UU	25	Rp 1"	10	0,49
VKR 025 F300-FF	VKR 025 F300-UU	25	Rp 1"	16	0,49
VKR 032 F320-FF	VKR 032 F320-UU	32	Rp 1 1/4"	10	0,73
VKR 032 F310-FF	VKR 032 F310-UU	32	Rp 1 1/4"	16	0,73
VKR 032 F300-FF	VKR 032 F300-UU	32	Rp 1 1/4"	25	0,73
VKR 040 F320-FF	VKR 040 F320-UU	40	Rp 1 1/2"	16	1,10
VKR 040 F310-FF	VKR 040 F310-UU	40	Rp 1 1/2"	25	1,10
VKR 040 F300-FF	VKR 040 F300-UU	40	Rp 1 1/2"	40	1,10
VKR 050 F320-FF	VKR 050 F320-UU	50	Rp 2"	25	1,76
VKR 050 F310-FF	VKR 050 F310-UU	50	Rp 2"	40	1,76
VKR 050 F300-FF	VKR 050 F300-UU	50	Rp 2"	63	1,76

Operating temperature <sup>2)</sup>	-10...130 °C	Dimension drawing	<a href="#">M10498</a>
Operating pressure	-10...50 °C 40 bar +130 °C 35 bar	Installation guide	
Valve characteristic	Equal-percentage	VKR	P100002038
Ball valve rangeability	500:1 (typical)	AKM105, 115S	P100001578
Rangeability with drive	> 50:1 (typical)	AKF112, 113S	P100002659
Leakage rate	0,001% of kvs value	Declaration on materials and the environment	MD 56.090
Rotation angle	90 °		

1) See engineering and fitting notes for open circuits

2) No stuffing box heater required at temperature of less than 0 °C, use temperature adapter at temperatures above 100 °C (accessory).

3) For air, low-pressure steam: DN40 - PN25, DN50 - PN20

**Accessories**

- 0510420 001\* Temperature adapter (>100 °C to max. 130 °C) for AKM and AKF, P100002660
- 0560283 015\* 1 screw fitting made from brass for DN 15 female thread
- 0560283 020\* 1 screw fitting made from brass for DN 20 female thread
- 0560283 025\* 1 screw fitting made from brass for DN 25 female thread
- 0560283 032\* 1 screw fitting made from brass for DN 32 female thread
- 0560283 040\* 1 screw fitting made from brass for DN 40 female thread
- 0560283 050\* 1 screw fitting made from brass for DN 50 female thread
- 0560332 015\* Strainer made from gun metal, -10 - 150°C, mesh aperture 0,5 mm, DN15
- 0560332 020\* Strainer made from gun metal, -10 - 150°C, mesh aperture 0,8 mm, DN20
- 0560332 025\* Strainer made from gun metal, -10 - 150°C, mesh aperture 0,8 mm, DN25
- 0560332 032\* Strainer made from gun metal, -10 - 150°C, mesh aperture 0,8 mm, DN32
- 0560332 040\* Strainer made from gun metal, -10 - 150°C, mesh aperture 0,8 mm, DN40
- 0560332 050\* Strainer made from gun metal, -10 - 150°C, mesh aperture 0,8 mm, DN50

\*) Dimension drawing or connection diagram available under same number

**Combination of VKR and electric rotary drive**

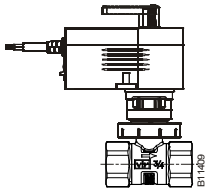

Drive Running time: Input:	AKM 105			AKM 115 F12.			AKM 115S
	35s 2-/3-pt			120s 2-/3-pt			35 / 60 / 120 s 2-/3-pt/0..10 V
Ball Valve	Against pressure			Against pressure			
	$\Delta p_{max}$	$\Delta p_s$	close/off pressure	$\Delta p_{max}$	$\Delta p_s$	close/off pressure	
VKR 015	1,8	-	-	3,5	-	-	
VKR 020	1,8	-	-	3,5	-	-	
VKR 025	1,8	-	-	3,5	-	-	
VKR 032	1,2	-	-	2,4	-	-	
VKR 040	1,2	-	-	2,4	-	-	
VKR 050	1,2	-	-	2,4	-	-	

**Combination of VKR and electric rotary drive with spring return**

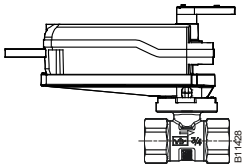

Drive Running time, Motor: spring: Input:	AKF 112 F120			AKF 112 F122	AKF 113 F122	AKF 113S F122
	90s 15s 2-pt - 230 V			90s 15s 2-pt - 24 V	90s 15s 3-pt - 24 V	90s 15s 0...10 V - 24 V
Ball Valve	Against pressure					
	$\Delta p_{max}$	$\Delta p_s$	close/off pressure			
VKR 015	3,5	5,4	-			
VKR 020	3,5	5,4	-			
VKR 025	3,5	5,4	-			
VKR 032	2,4	3,5	-			
VKR 040	2,4	3,5	-			
VKR 050	2,4	3,5	-			

Valve: F variant, see valve type table for technical data and accessories

Drives: F variant, see section 51 for technical data, accessories and installation position

Example: VKR 015 F310 / AKM 115S F132

$\Delta p_{max}$ [bar]	Maximum permissible pressure difference across the valve at which the drive can still reliably open and close the valve taking $\Delta p_v$ into consideration.
$\Delta p_s$ [bar]	Maximum permissible pressure difference across the valve in the event of a problem (pipeline break downstream of valve) at which the drive can reliably close with "fast" stroke passage
close/off pressure	Maximum possible pressure difference across the valve during control operation at which the drive can still open and close the valve. A shorter service life can be expected if this method is used. Cavitation, erosion and pressure surges can damage the valve. The values only apply to the assembled combination of the valve fitted to the drive.

**Function**

The control ball valve can be controlled to any intermediate position using an electric drive. Closing against the operating pressure is possible with the AKM 105, 115(S) drive or the valve drive with spring return AKF 112, 113(S), and closing with the operating pressure is not permitted.

Closing against the pressure



**Description**

These control ball valves are characterised by being extremely reliable and accurate, and make a considerable contribution to providing environmentally friendly control. They comply with the most demanding requirements such as a quick-closing function, coping with differential pressures, controlling media temperatures and providing a shut-off facility – all with a low-noise design.

The spindle of the ball valve is automatically connected to the axle carrier of the drive. The brass ball regulates an equal-percentage flow in the control branch. The tightness of the ball is safeguarded by the PTFE collar that is inserted into the body. An EPDM O-ring is inserted behind these two collars. These O-rings permit the ball and both collars to make a small axial movement that provides an extremely good seal and generates little torque.

The tightness of the spindle is safeguarded by 2 O-rings that cannot be replaced if leakage occurs.

**Engineering and fitting notes**

The valves are combined with the rotary drives with or without spring return. The drive is directly attached to the ball valve and held in place by a bayonet connection. The drive axle is connected to the spindle automatically, for which purpose the axle of the ball valve must be in an intermediate position. During the commissioning of the system the SUT drive moves to the open position and both devices are connected automatically. The rotation angle of the ball valve is also detected by the drive, meaning that no other settings are required. The characteristic curve of the SUT drives can be set to linear or quadratic. In order to prevent the ball valve from blocking in the final position, the SUT drive makes a rotation angle movement of approx. 30° if the output signal has not changed at the final positions for about 3 days.

In order to prevent impurities from being retained in the water (e.g. welding beads, rust particles etc.) and damaging the PTFE collar, strainers must be installed on each floor or in each feed pipe. For strainers see accessories, pay attention to usage and temperature range for each model. For water requirements see VDI 2035.

All ball valves must only be used in closed circuits. Excessive oxygen content in open circuits can destroy the valve. In order to prevent this, an oxygen binding material must be used; the manufacturer of the solution must be consulted with regard to compatibility in order to prevent corrosion. The material list can be used for this purpose.

The fittings are usually insulated in the systems. Care must be taken not to insulate the flange that holds the drive when doing this.

In order to prevent disturbing flow noise in quiet rooms, the pressure difference across the valve must not exceed 50% of the specified values.

The crank handle is fixed to the drive. In order to operate the crank handle the manual adjustment knob on the drive must be pushed downwards. The drive will not operate until this knob is moved back to the upper position. There is also a square on the crank handle that matches the square of the ball valve spindle.

**Use with water**

When water is being used that has been mixed with glycol or inhibitor, compatibility with the materials and seals in the valve should be clarified with the manufacturer for safety reasons. The table of materials shown below can be used for this purpose. We recommend using a concentration of between 20% and 50% when glycol is being used.

The valves are not suitable for use in potentially explosive areas. The materials that have been selected are approved for use with drinking water. The entire valve as a unit is not certified for use with drinking water.

**Installation position**

The final control element can be installed in any position, but a suspended installation position is not recommended. Condensation and dripping water must be prevented from penetrating the drive.

**Flow-rate chart**

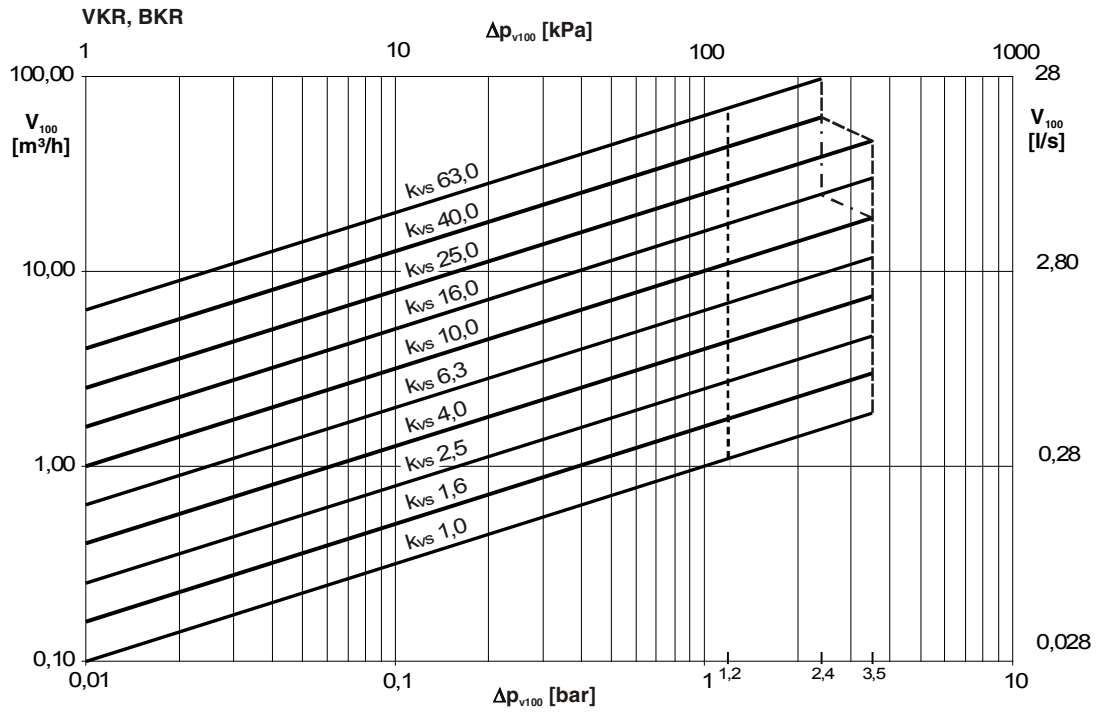

.....  $\Delta p_v = 1,2$  bar  
 Luft, Niederdruckdampf  
 Air, vapeur basse pression  
 Air, low pressure steam

- - - -  $\Delta p_v = 3,5$  bar  
 Wasser, Wasser-Glykol  
 Eau, eau-glycol  
 Water, water-glycol

- · - ·  $\Delta p_v = 2,4$  bar  
 VKR / BKR 032 F300  $k_{vs}25$   
 VKR / BKR 032 F310  $k_{vs}16$   
 VKR / BKR 040 F310  $k_{vs}25$

B11257

**Additional technical data**

**Technical Information**

Pressure and temperature specifications  
 Fluidic parameters  
 Technical handbook "Actuators"  
 Parameters, installation instructions, control, general

EN 764, EN 1333  
 EN 60534 Page 3  
 7 000477 003  
 Applicable EN, DIN  
 instructions  
 97/23/EC Clause 3.3

Pressurised equipment CE conformity directive, no CE symbol (fluid group II)

**Additional design specifications**

The body of the ball valve is made from DZR hot-pressed brass (EN 12165) with cylindrical female thread in acc.with ISO 7/1 Rp. Axle seal with double ethylene propylene O-ring.

**DIN material numbers**

	DIN material number	DIN designation
Body of ball valve	CW602N	CuZn36Pb2As
Connector	CW602N	CuZn36Pb2As
Ball, polished, chrome plated	CW602N	CuZn36Pb2As
Axle	CW602N	CuZn36Pb2As
O-Ring	EPDM	
Collar	PTFE	

### Supplementary information concerning pressure difference definitions

#### $\Delta p_V$ :

Max. permitted pressure difference across the valve for each stroke position, restricted by noise level and erosion.

This parameter specifically characterises the hydraulic behaviour of the valve as an element that is flowed through. The service life and usability of the valve is improved by monitoring cavitation and erosion and the associated noise generation.

#### $\Delta p_{max}$ :

Maximum permitted pressure difference across the valve at which the drive can open and close reliably.

The following are taken into consideration: static pressure and fluidic influences. Problem-free stroke passage and tightness are guaranteed with this value. However, the value must not be less than the  $\Delta p_V$  value for the valve.

#### $\Delta p_S$ :

Max. permitted pressure difference across the valve in the event of a problem (e.g. power failure, excessive temperature or pressure, pipe break) at which the drive can close and seal the valve and maintain the entire operating pressure against atmospheric pressure if necessary. Since this is a quick-closing function with "fast" stroke passage,  $\Delta p_S$  can be greater than  $\Delta p_{max}$  or  $\Delta p_V$ . The interfering fluidic effects that occur in this case are quickly run through and are of lesser importance when this method is being used.

The values only apply to the control load in three-way valves.

#### $\Delta p_{stat}$ :

Line pressure downstream of the valve. Essentially corresponds to the dead pressure with the pump switched off, e.g. caused by the height of the liquid in the system, pressure increased caused by pressure tanks, steam pressure etc.

The static pressure of valves that close with pressure must be added to the pump pressure before use.

### Characteristic curve for drives with positioners

On drive AKM 115S

Equal-percentage / linear / quadratic

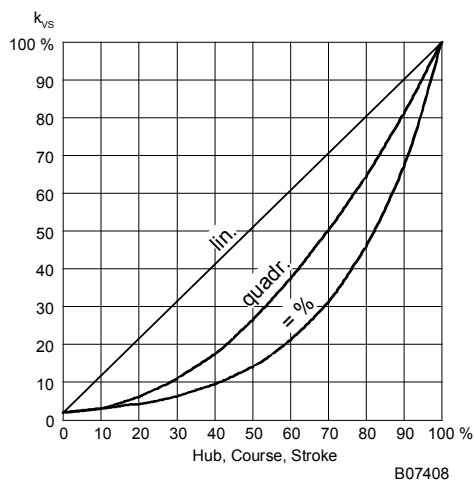

Dimension drawings

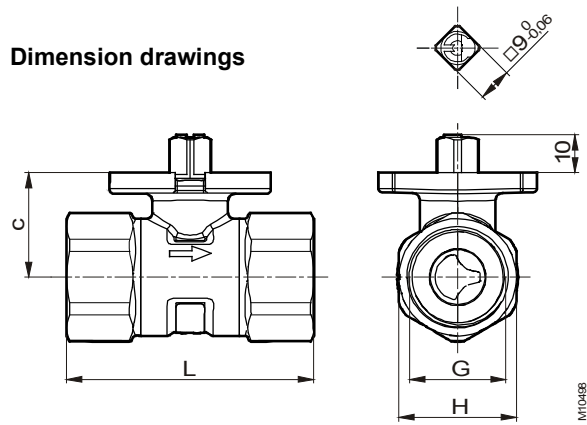

DN	c mm	G inch	L mm	H mm
15	27,6	Rp 1/2	61,6	26
20	27,6	Rp 3/4	67,4	31
25	30,5	Rp 1	76,8	39
32	34,3	Rp 1 1/4	88,0	48
40	39,8	Rp 1 1/2	101,8	55
50	52,8	Rp 2	116,2	67

Combinations

AKM 105, 115(S)

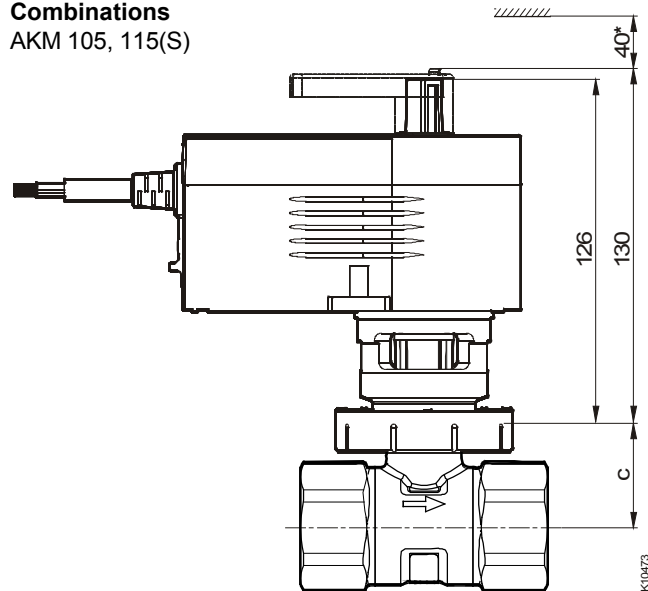

\* with accessory 0510480 00 . : 72 mm

AKF 112, 113(S)

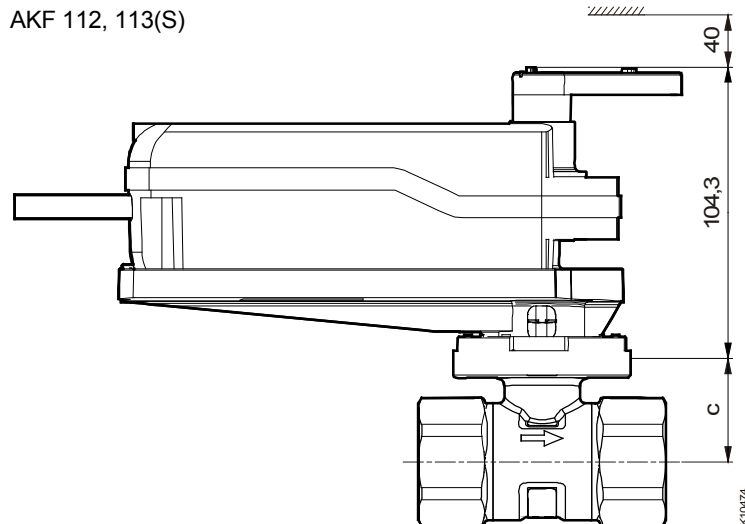

## Accessories

0560332 0 . .

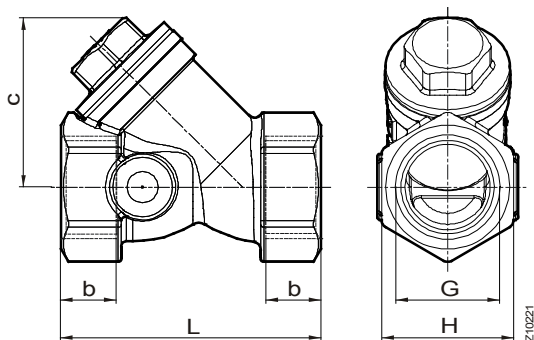

DN	b mm	c mm	G inch	L mm	H mm
15	12	38	G 1/2	54	27
20	15	43	G 3/4	67	34
25	16	53	G 1	79	41
32	17	64	G 1 1/4	98	51
40	18	70	G 1 1/2	106	57
50	20	85	G 2	122	69

0560283 0 . .

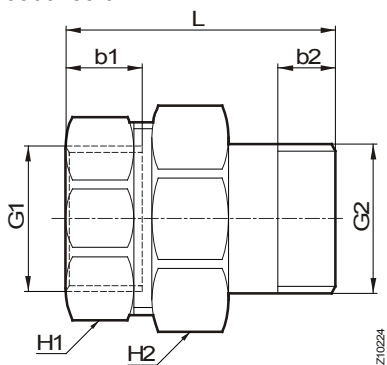

DN	b1 mm	b2 mm	G1 inch	G2 inch	L mm	H1 mm	H2 mm
15	10	10	Rp 1/2	G 1/2	46	26	30
20	12	12	Rp 3/4	G 3/4	52	31	37
25	14	14	Rp 1	G 1	60	40	46
32	16	16	G 1 1/4	G 1 1/4	65	50	54
40	17	17	G 1 1/2	G 1 1/2	76	54	64
50	20	20	G 2	G 2	98	69	81

0510420 001

